

Sonoma Series™ PREMIUM

Assembly Instructions for 2 and 3 leg Tables

Sonoma Series™ PREMIUM Workcenters

PARTS LISTING

NOTE: The quantities listed vary depending on whether it is a two or three leg table

Top (size and shape differ for each model)
If Workrite is not supplying the top, it is installer's responsibility to position the base under the worksurface to provide maximum stability.



Feet (2 or 3)

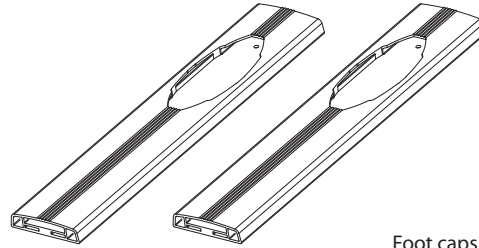

Leg Assemblies (2 or 3)

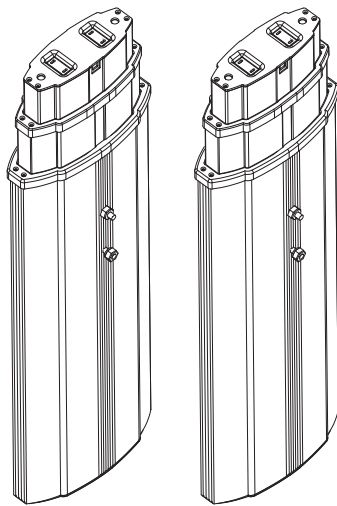

Nuts and lock washers are already threaded onto studs

Foot caps (4 or 6)

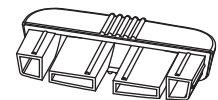

Cables (2 or 3)

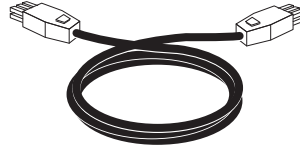

Control Box

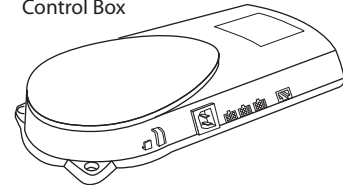

Power Cord

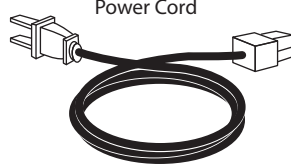

Control Panel with 2 attachment screws

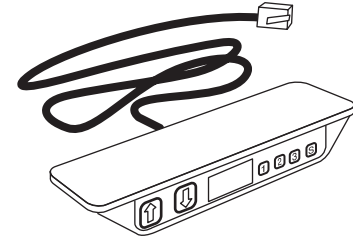

Crossbar (1 or 2)

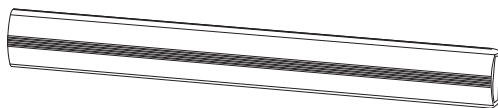

Cable Spool & #8 x1" wood screw (1 per leg)



Top Brackets (2 or 3)

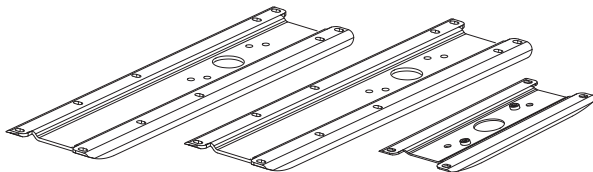

Top Bracket for center leg if a three leg table

Velcro Cable Strap (1 per leg)



Crossbar Brackets (2 or 3)

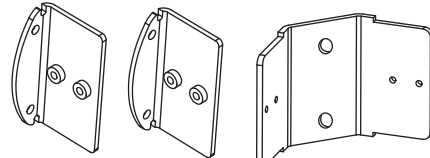

Crossbar Bracket for center leg if a three leg table

5/32" Allen Wrench



Wood screws (24 or 28)



3/4" Button Head machine screws (12 or 20) and lock washers (12 or 20)

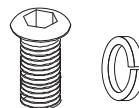

Leveling Glides (4 or 6)



Acorn Nuts (2)
For three leg tables only



Stiffening Brackets (2)
For two leg tables only

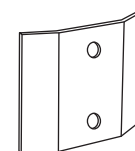

ASSEMBLY INSTRUCTIONS

OPEN ALL PACKAGES AND VERIFY THAT YOU HAVE ALL THE HARDWARE AS INDICATED IN THE PARTS LISTING.
To assemble you will need a #3 tip Philips screwdriver and a 7/16" wrench or socket.

STEP 1

Remove and discard Phillips head transit screws from sheet metal plates at both ends of leg assembly.

Attach Top Bracket to smallest end of each leg assembly using 3/4" button head machine screws. This end is up and attaches to the underside of the worksurface.
Note: if table has three legs, the center leg uses the short Top Bracket.

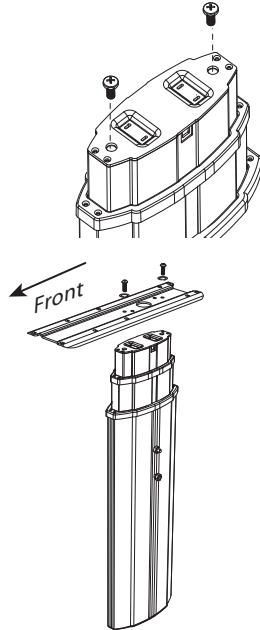

STEP 2

Insert Foot Caps into ends of foot. Screw in Leveling Glides. Slide foot onto Leg Assembly and attach with button head machine screws. Note that the longest end of the foot extends to the front edge of the worksurface.

Note: if table has three legs, the center leg uses the short Foot.

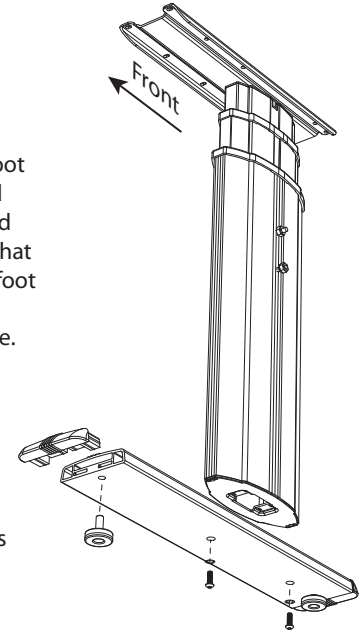

STEP 3

Remove nuts and lock washers from leg studs. If 2-leg table, Slide Stiffening Bracket onto studs, slide Crossbar Bracket onto studs and reinstall nuts (no lock washers). Note how the flange orients to the leg.

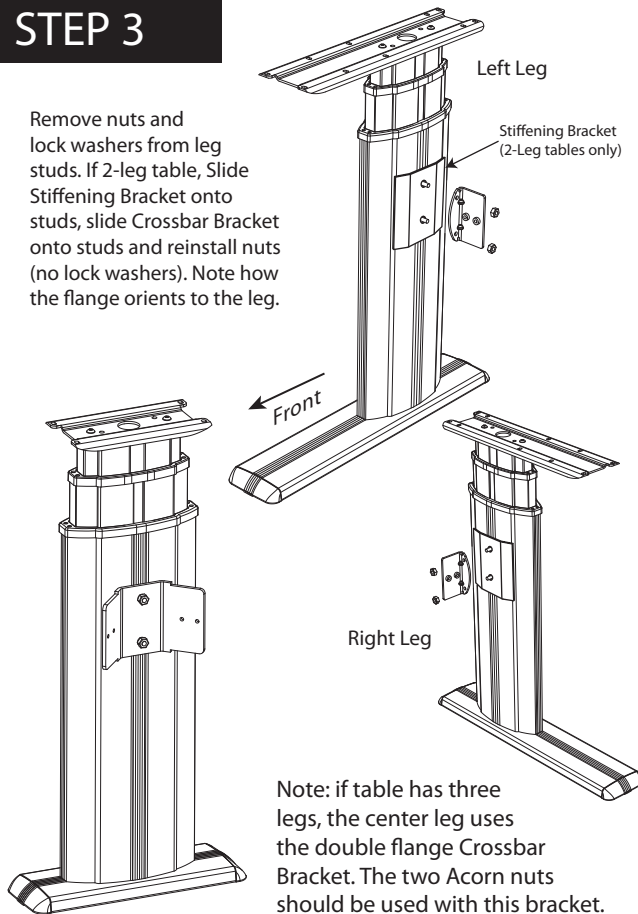

Note: if table has three legs, the center leg uses the double flange Crossbar Bracket. The two Acorn nuts should be used with this bracket.

STEP 4

Place assembled legs onto the underside of the worksurface in their approximate location. Note that mounting holes have been pre-drilled to match the top bracket.

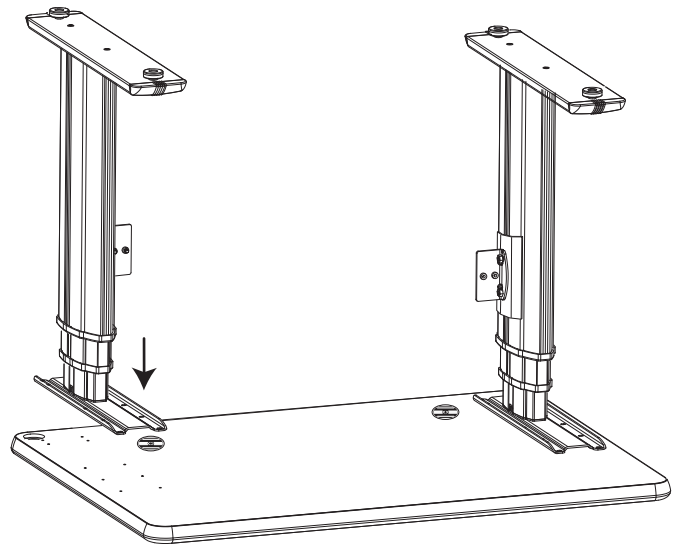

ASSEMBLY INSTRUCTIONS

STEP 5

Slide Crossbar onto Crossbar Brackets and attach with two machine screws to each bracket.

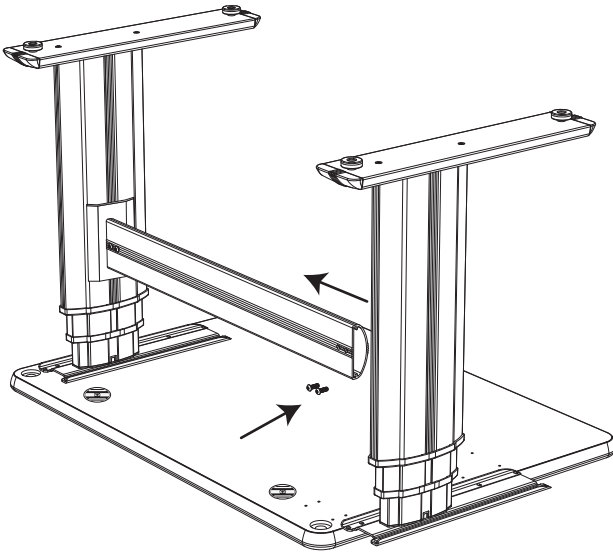

3 LEG

If you are assembling a three leg table, note that the middle leg is oriented at a 45° angle. The side with the double flange Crossbar Bracket faces the front edge of the table.

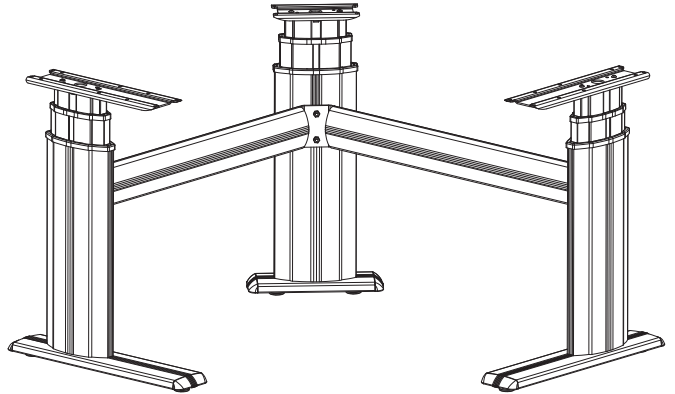

STEP 6

Attach Top Brackets to underside of the worksurface. Note: do not fully tighten screws. Screw cable spools to underside of worksurface. Note that the attachment locations are marked with labels.

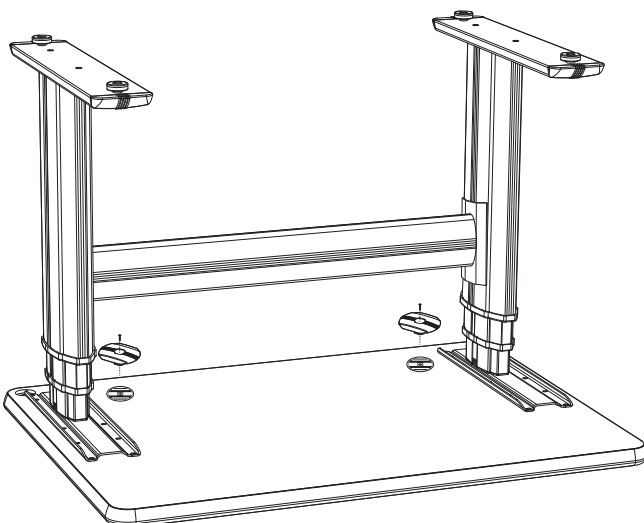

STEP 7

Attach Control Box and Control Panel to the underside of the worksurface. Mounting holes are provided. Plug leg cables into control box. NOTE: There are three 6-pin female connectors on the control box. On a 2-leg table, connect the leg cables to the middle and furthest to the right connectors from the power cable. To insure that cables fit tight to the underside of worksurface, wrap excess cable length around spools as required. Plug leg cables into plugs extending from legs. Wrap Control panel cable around spool as required and plug into Control Box. Use velcro straps to take up remaining slack in cables.

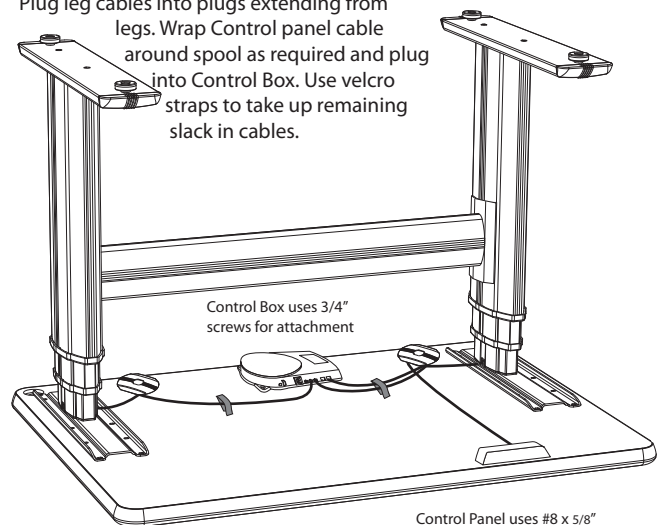

ASSEMBLY INSTRUCTIONS

STEP 8

Flip table over and adjust leveling glides so that the table does not wobble. Run table up and down one time and then tighten all top bracket screws.

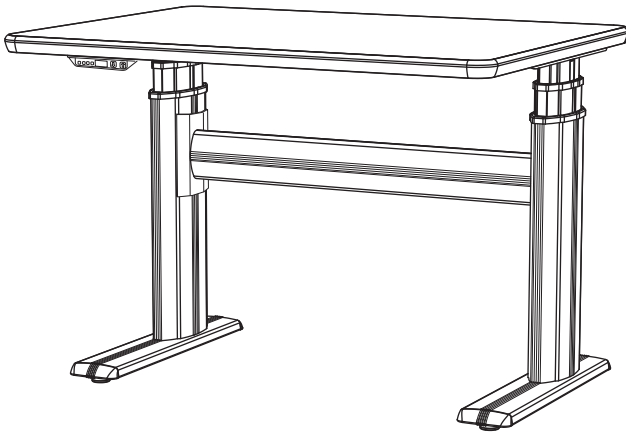

STEP 9

It may be necessary to adjust the display height readout. The low height will vary depending on the flooring surface and adjusted height of the leveling glides. To obtain an accurate readout, lower the table to its lowest position and measure from the floor to the top of the worksurface.

Change the display by pressing and holding the "S" button, hit the UP or DOWN button until the display shows the correct height.

