



SwingArm-Dual™ Assembly Instructions

Workrite
ergonomics®

Important Safety Instructions

Read and understand all these safety instructions before using this product.

Do not mount the clamp base or the grommet base on an unstable surface (any surface that will not hold the base firmly).

For safety reasons, the internal gas-strut of the SwingArm–Dual™ is pre-adjusted at the factory to the lowest force for the prevention of arm body recoil during installation.

IMPORTANT SAFETY PRECAUTION:

During installation, beware that the arm body can move suddenly when attaching or detaching the LCD monitor to the Swing. **WHEN CHANGING THE LCD MONITOR, ALWAYS RE-ADJUST THE GAS STRUT TO THE LOWEST FORCE SETTING.** Without this adjustment, the arm will move suddenly upward when the monitor is removed.

Do not attempt to disassemble, service or modify the product yourself.

Use only a slightly damp cloth to clean the Arm surface. Never use flammable solvents like alcohol, benzene, thinner, etc.

Table of Contents



List of Boxes	3
List of Parts	3
Step 1: Attach Clamp Base to Work Surface	6
Step 1x: Attach Grommet Base to Work Surface	6
Step 2: Attach Monitor Arms to Monitors	7
Step 3: Attach Pivot Base and Arms	8
Step 4: Vertical Movement Adjustment	9
Step 5: Ball-joint Adjustment for Tilt Action	9
Step 6: Final Touches: Cable Management	10

List of Boxes





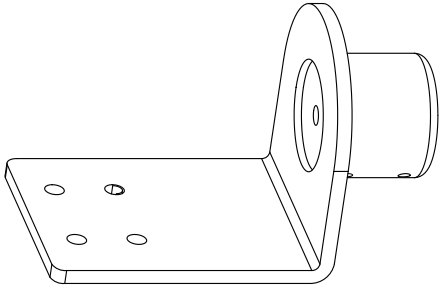
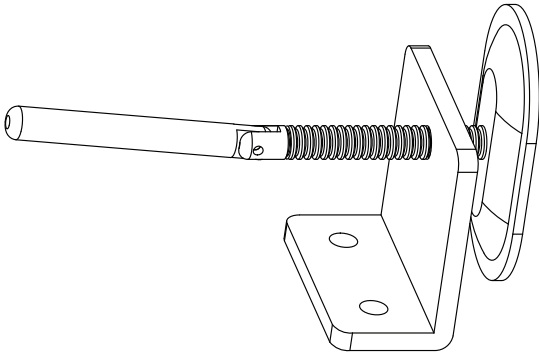
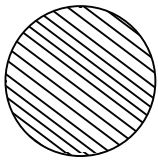

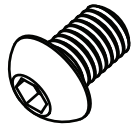



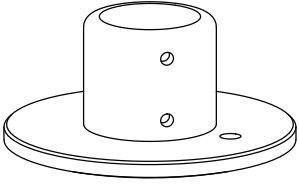

Box #	Label	Qty
I	Desk Clamp	1*
Ix	Desk Bolt	1*
II	Short Pole	1
III	Dual Mount	1
IV	Monitor Arm	2

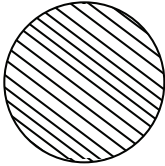

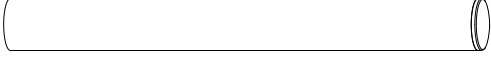
* Note that either Box I or Box Ix will be included, depending on the style of base purchased.

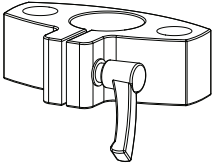
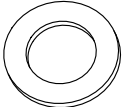
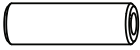
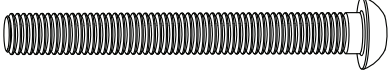
List of Parts

Part	Illustration	Box	Description	Qty
I-1		I	Clamp Base	1
I-2		I	Clamping bracket	1
I-3		I	Base cushion	1
I-4		I	M5 hex wrench	1
I-5		I	M2.5 Hex Wrench	1
I-6		I	Button head cap screw M8 X 1.25 X 15mm	2

SwingArm-Dual™ Installation Instructions

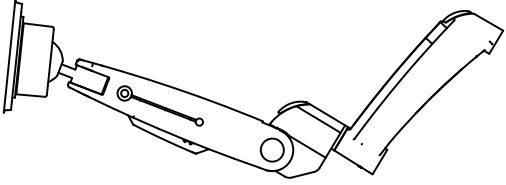
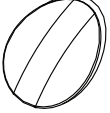
Part	Illustration	Box	Description	Qty
Ix-1		Ix	Grommet Base	1
Ix-2		Ix	U-Bracket	1
Ix-3		Ix	M8 X 1.25 X 130mm Thread Rod	1
Ix-4		Ix	M8 Washer	1
Ix-5		Ix	M8 X 1.25 Wing Nut	1
Ix-6		Ix	Base cushion	1
Ix-7		Ix	M5 hex wrench	1
Ix-8		Ix	M2.5 Hex Wrench	1
II-1		II	14" Pole	1
II-2		II	Cable manager Velcro® strips	2
III-1		III	Dual Mount Clamp	1
III-2		III	Plastic Spacer 30mm OD, 18.5 mm ID	2
III-3		III	Pivot Pins 55mm	2
III-4		III	Button-head Cap Threaded Bolt M8 X 1.25 X 70mm	2
III-5		III	Set Screws M5 X .8 X 10mm	2
III-6		III	M8 Disc Spring Washer 23mm OD, 8.2 mm ID	2
III-7		III	Flat M8 Washer 16mm OD	2

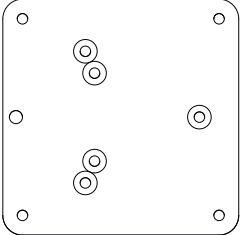
Part	Illustration	Box	Description	Qty
IV-1		IV	Assembled arm	2*
IV-2		IV	End Cap	2*
IV-3		IV	Round-head screw M4 X 0.7 X 10mm	8*
IV-4		IV	Round-head screw M4 X 0.7 X 6mm	8*
IV-5		IV	75mm Monitor plate	2*

* Quantities for Box IV parts show total from both boxes

Workrite reserves the right to make changes to its products without notice. No liability is assumed for any misprinting or error in this publication. Copyright 2008. All rights reserved.

Step 1: Attach Clamp Base to Work Surface

(If you are using the grommet base, please skip to Step 1x.)

- A: Attach the base cushion (I-3) to the underside of the base (I-1).
- B: Attach 14" pole (II-1) to base, securely tighten 4 set screws (already in place).
- C: If there is not enough clearance to fit the assembled base between the back of the work surface and the wall, place the clamp base on the desk edge before attaching the clamping bracket (I-2) from below. Otherwise, attach the clamping bracket with 2 button-head cap screws (I-6) before placing the base on the work surface.

Use the upper set of holes on the bracket for work surfaces between 1/2" and 1 1/4" thick, and use the lower set for work surfaces between 1 1/4" and 2 1/4" thick.

- D: Tighten the clamping bracket until it is firmly clamped to the work surface.
- E: Skip to step 2.

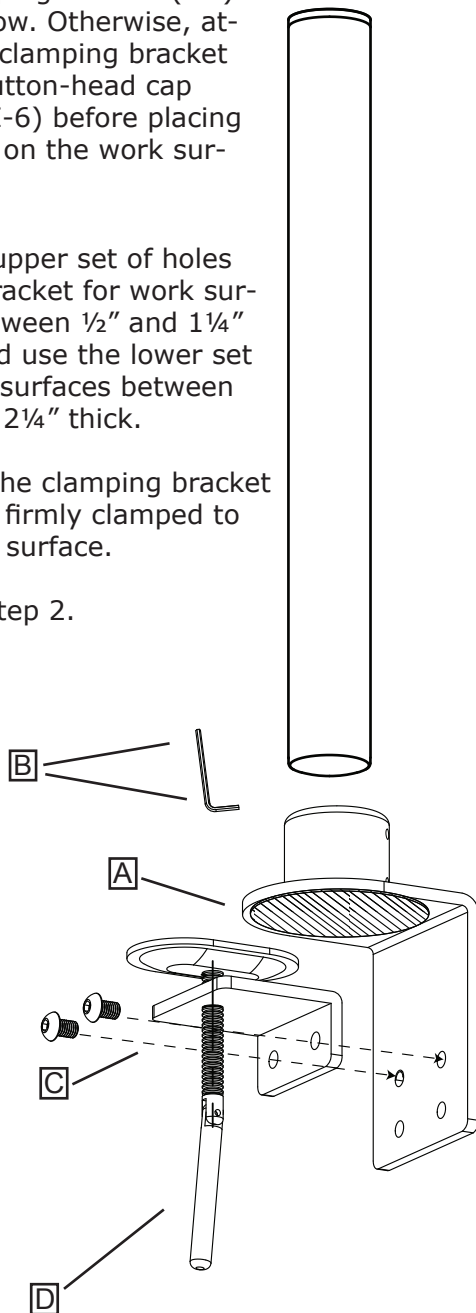

Step 1x: Attach Grommet Base to Work Surface

- A: Remove the center hole from the base cushion (Ix-6), then attach it to the underside of the base (Ix-1), aligning the hole in the base with the hole in the protector. Thread the M8 Thread Rod (Ix-3) into the bottom of the base.
- B: Attach 14" pole (II-1) to base, securely tighten 4 set screws (already in place).
- C: Place the base on the work surface, centering it over a bolting hole from 3/8" to 3" in diameter.
- D: Position the U-Bracket (Ix-2) and Small Washer (Ix-4) onto the M8 Thread Rod and secure the bracket by tightening the Wing Nut (Ix-5).
- E: Proceed to step 2.

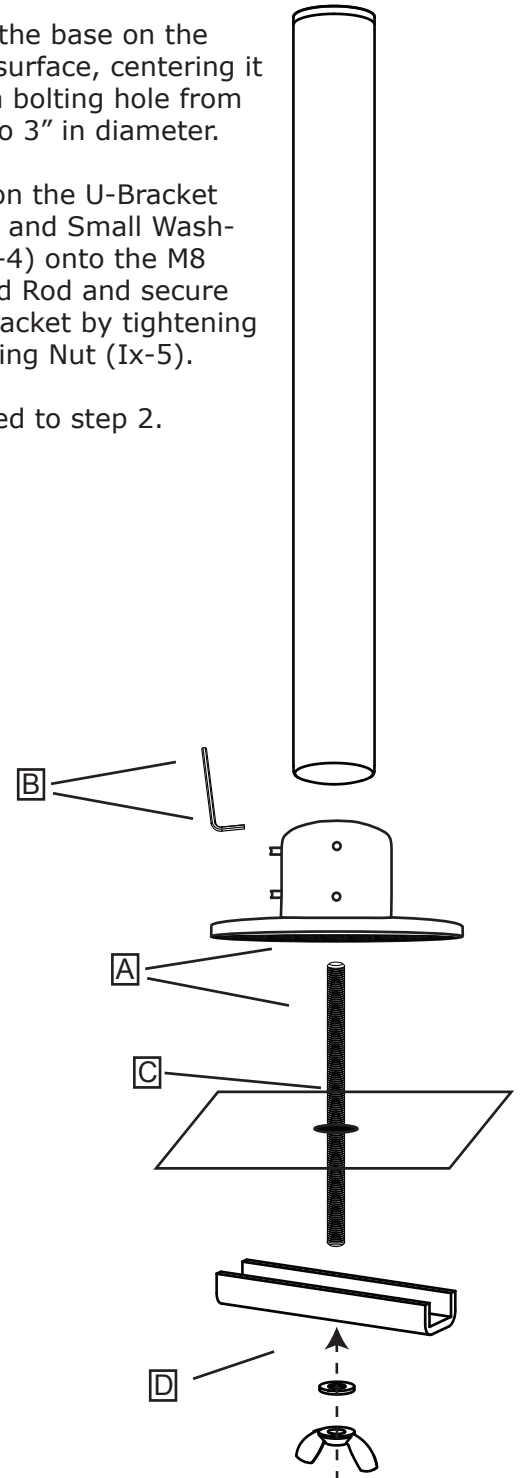

Step 2: Attach Monitor Arms to Monitors

- A: Place monitor carefully on a clean, flat surface, face down.
- B: Attach the monitor arm (IV-1) to the back of the monitor with four screws, using a Phillips-head screwdriver (not included). Use the mounting screws provided by your monitor manufacturer if available. Otherwise, use the screws provided that best fits your monitor (IV-4 or IV-5).

If the mounting area on your monitor is smaller than the 100mm VESA connecting plate and is recessed, remove the plate and replace it with the smaller 75mm plate (IV-6). Then attach the plate to the back of the monitor.

- C: Repeat A & B for the second monitor.

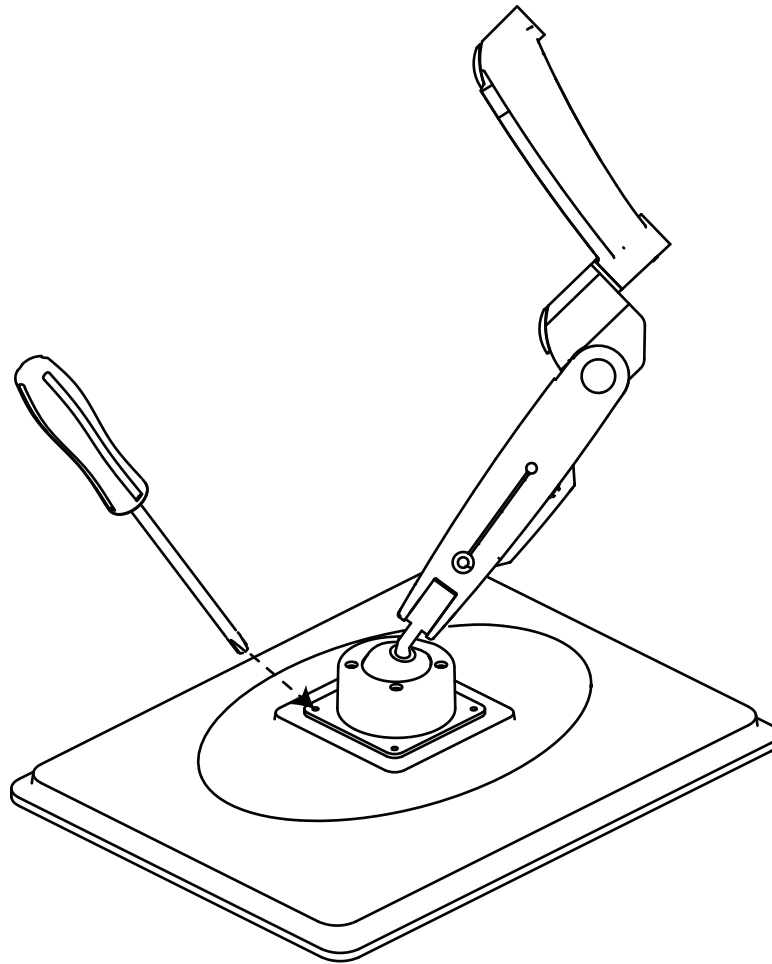

Step 3: Attach Pivot Base and Arms

- A: Place the pivot pins (III-3) and the large plastic spacers (III-2) onto the dual mount clamp (III-1).
- B: Place the dual mount clamp assembly onto the pole with the ratchet handle facing the back. Position the mount so that the top of it is approximately 7" from the desk for a 15" monitor, 8" for a 17" monitor or 9" for a 19" monitor. Tighten the dual mount using the ratcheting handle. Pull the handle out to release and rotate to allow for additional turns to tighten.
- C: Attach one assembled monitor arm to the dual mount clamp. Position the arm horizontally and test the height range to be sure it is correct for your monitor. If not, remove the arm and move the dual mount clamp accordingly. Then replace the arm. Attach the second arm to the dual mount clamp.

NOTE: Remove the monitor arms before adjusting the clamp height to avoid scratching the finish of the pole

- D: Secure the monitor arms by placing the small flat washer (III-7) on the 70mm threaded bolt (III-4), followed by the larger disc spring washer (III-6), with the concave side facing away from the bolt head (down), and then placing the bolt with the washers into the hole on the end of the monitor arm, tightening with the M5 hex wrench. Tighten to a light friction so that the arm can turn, but not too loosely.
- E: Install and tighten the set screws in the dual mount with the M2.5 hex wrench to lock the 70mm bolts.
- F: Press the end caps onto the ends of the monitor arms, covering the 70mm bolts.

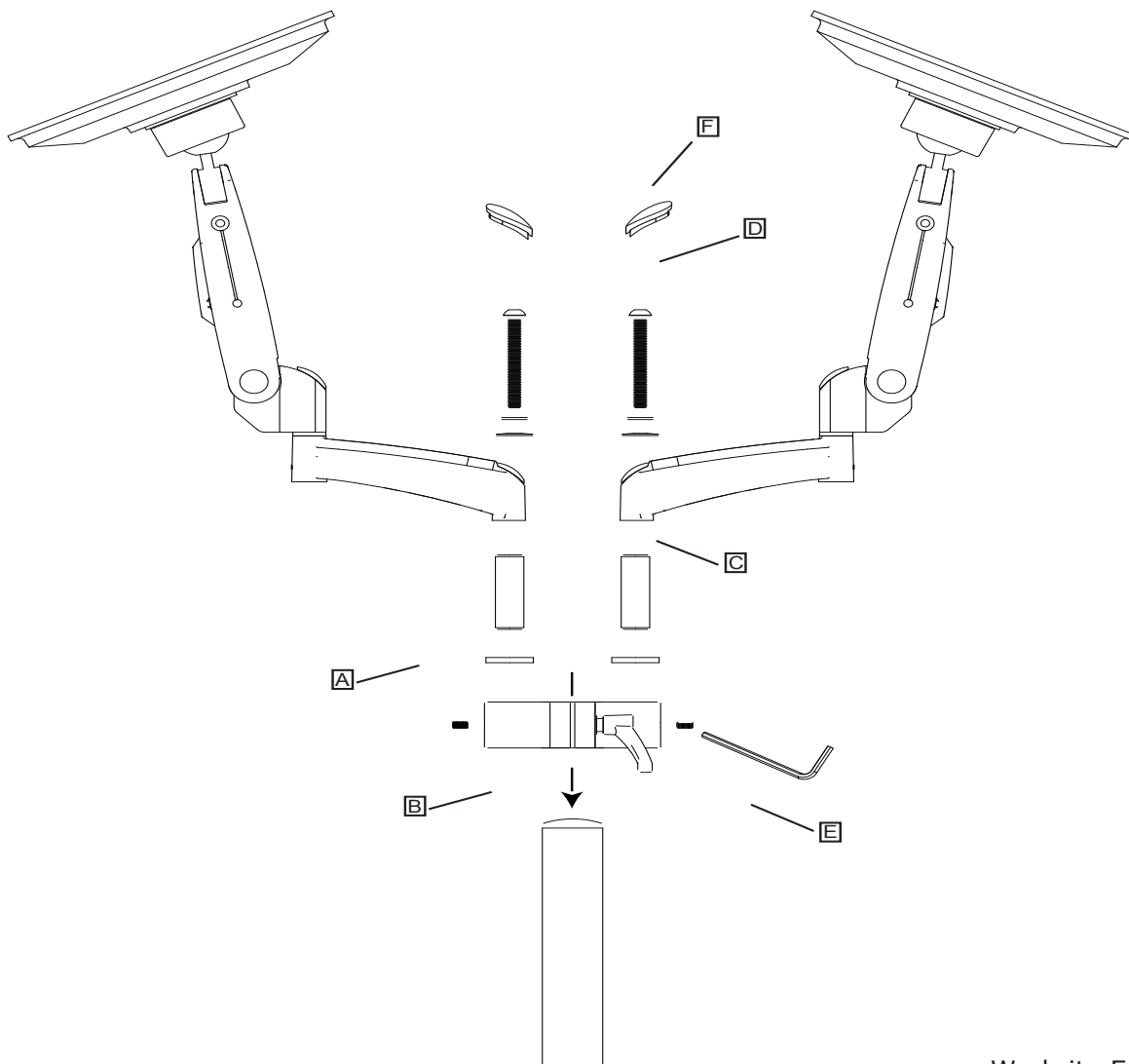

Your SwingArm—Dual is now installed and it is time for the final adjustments. If your monitor is too light or too heavy for the factory-set tension, the arm will raise or lower too easily (or even on its own). If this is the case, you need to adjust the vertical movement.

Step 4: Vertical Movement Adjustment

- A: Set the monitor arm at a 90° angle and locate the adjustment screw on the top of the arm joint.
- B: If the arm tends to rise, turn the adjustment screw **clockwise** using the M5 hex wrench, decreasing tension until the arm reaches a stable, balanced adjustment.
- C: If the arm tends to drop, turn the adjustment screw **counterclockwise** using the M5 hex wrench, increasing tension until the arm reaches a stable, balanced adjustment. With too much tension on the arm, the arm will tend to rise.
- D: To prevent damage to the arm, remove the hex wrench after adjustment.

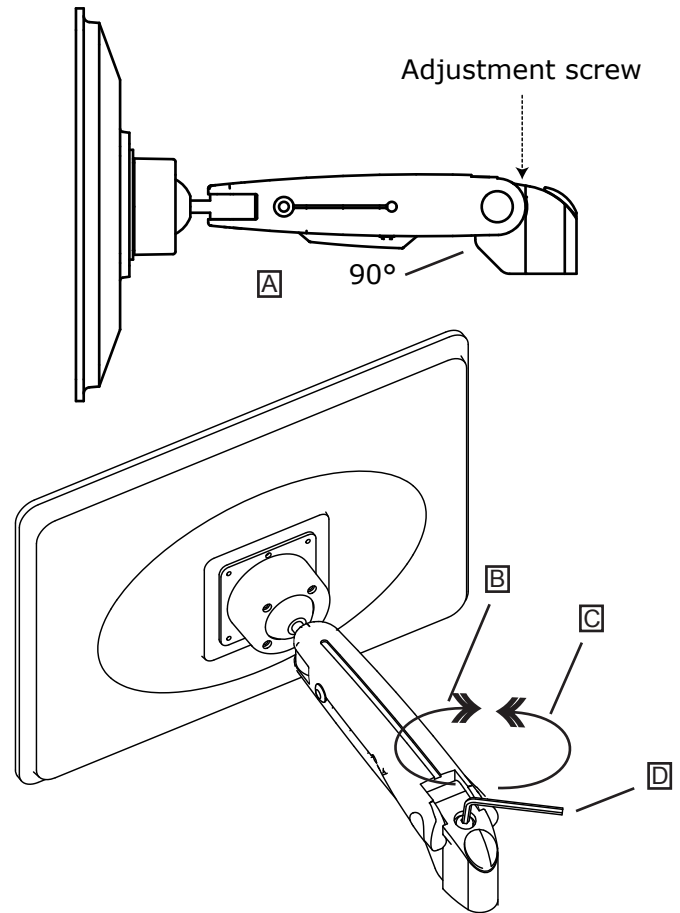

Step 5: Ball-joint Adjustment for Tilt Action

- A: If the monitor is too tight or too loose on the ball-joint, adjust the tension by turning the four screws closest to the ball one quarter turn each*, clockwise to tighten or counterclockwise to loosen.
- B: Repeat as necessary.

* It is important to turn them in very small increments and turn each of the four screws the same amount until the desired tension is achieved.

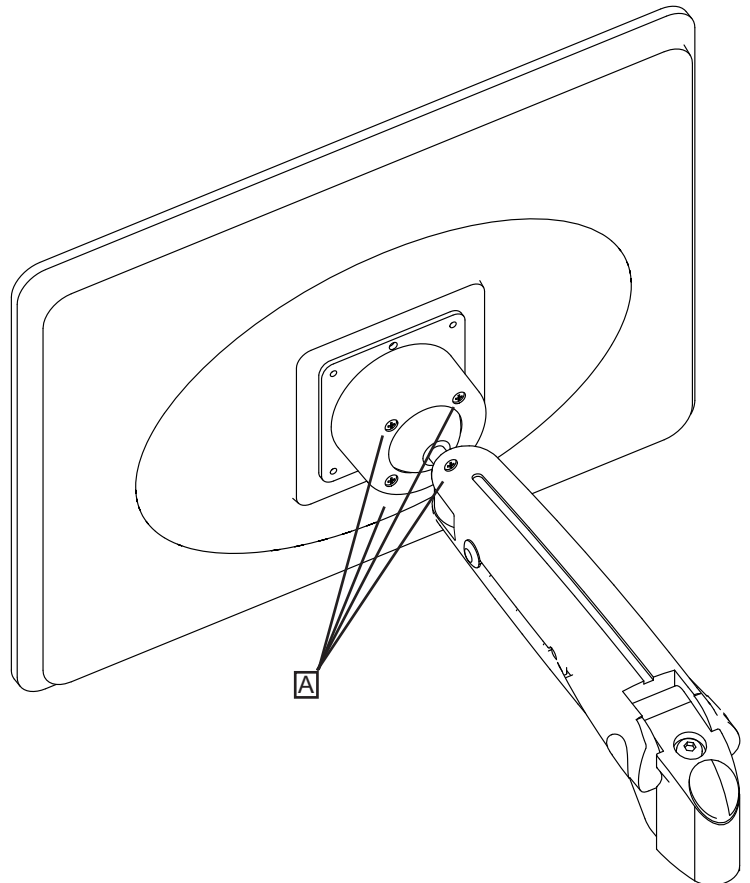

Step 6: Final Touches: Cable Management

- A: Thread the monitor cable through the plastic sleeve mounted on the lower side of the monitor arm, taking care to leave enough slack in the cable for full monitor movement on both sides of the sleeve.

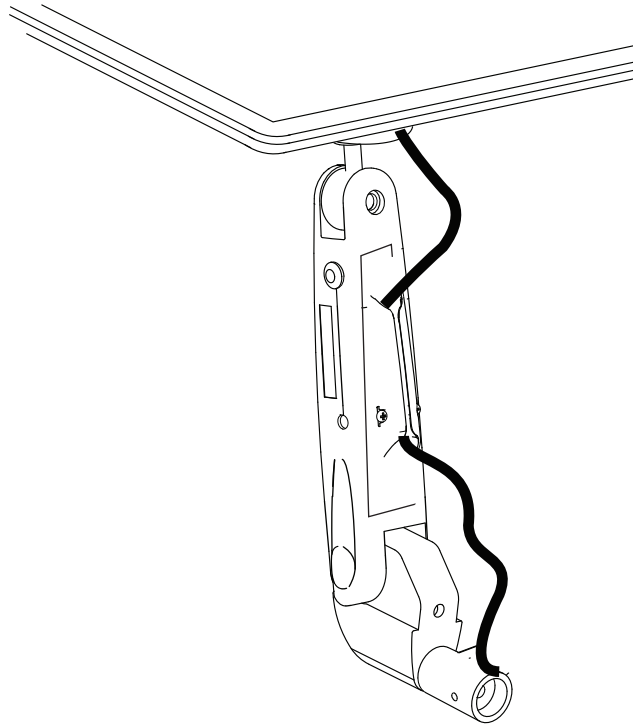

- B: Secure attached hook and loop strips around monitor cables, again leaving enough slack at both ends of the arm for full movement of the arms.

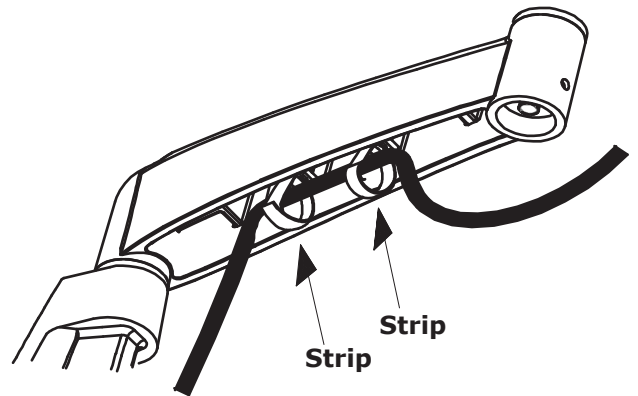

- C: Attach the monitor cables to the pole and secure with the Velcro® straps, again leaving enough slack between the extension arm and the pole for full movement of the arm.

