

# SteadyArm®

---

## Assembly Instructions

# List of Parts, grouped by carton

## Clamp Mount

For SKUs ending in "-C"

**A** Clamp Base  
Qty: 1

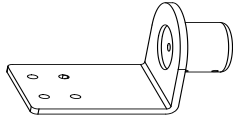

**B** Clamping Bracket  
Qty: 1

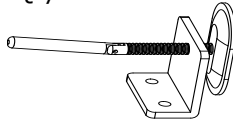

**C** Base Cushion  
Qty: 1

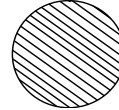

**D** M5 Hex Wrench  
Qty: 1



**E** M2.5 Hex Wrench  
Qty: 1



**F** Button head cap screw M8 X 1.25 X 12mm  
Qty: 2



## Grommet Mount

For SKUs ending in "-G"

**A** Grommet Base  
Qty: 1

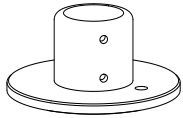

**B** U-Bracket  
Qty: 1



**C** Base Cushion  
Qty: 1

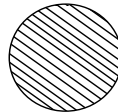

**D** M5 Hex Wrench  
Qty: 1



**E** M2.5 Hex Wrench  
Qty: 1



**F** M8 Washer  
Qty: 2



**G** Wing Nut  
Qty: 2



**H** M8 X 1.25 X 130mm Thread Rod  
Qty: 1



**I** M8 X 1.25 65mm Strengthening Bolt  
Qty: 1



## Pole

**J** 28" Pole or 14" Pole  
Qty: 1

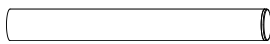

**K** Cable manager hook-and-loop strips  
Qty: 2



## Single Pivot

For SKUs starting with "2", Qty 2  
For SKUs starting with "1", Qty 1

**L** Pole Mount with Pivot  
Qty: 1

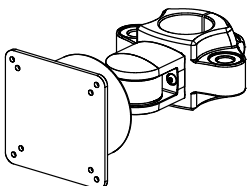

**M** Long Round-head screw  
M4 X 0.7 X 10mm  
Qty: 4



**N** Short Round-head screw  
M4 X 0.7 X 6mm  
Qty: 4



# 1 Verify that you have all the hardware and tools needed for the assembly

Check your cartons against the lists on page 2 to verify that you have all the parts needed.

You will also need the following tools:

#3 tip Phillips screwdriver

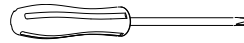

## 2 Install Pole and Clamp Base

For Grommet Base, skip to Step 3.

- a** Attach the base cushion to the underside of the base.
  - b** Attach pole to base, securely tighten 4 set screws (already in place).
  - c** If there is not enough clearance to fit the assembled base (parts A & B) between the back of the work surface and the wall, place the clamp base on the desk edge before attaching the clamping bracket from below. Otherwise, attach the clamping bracket with 2 button-head cap screws before placing the base on the work surface.
- Use the upper set of holes on the bracket for work surfaces between ½" and 1¼" thick, and use the lower set for work surfaces between 1¼" and 2¼" thick.
- d** Tighten the clamping bracket until it is firmly clamped to the work surface.

Skip to Step 4.

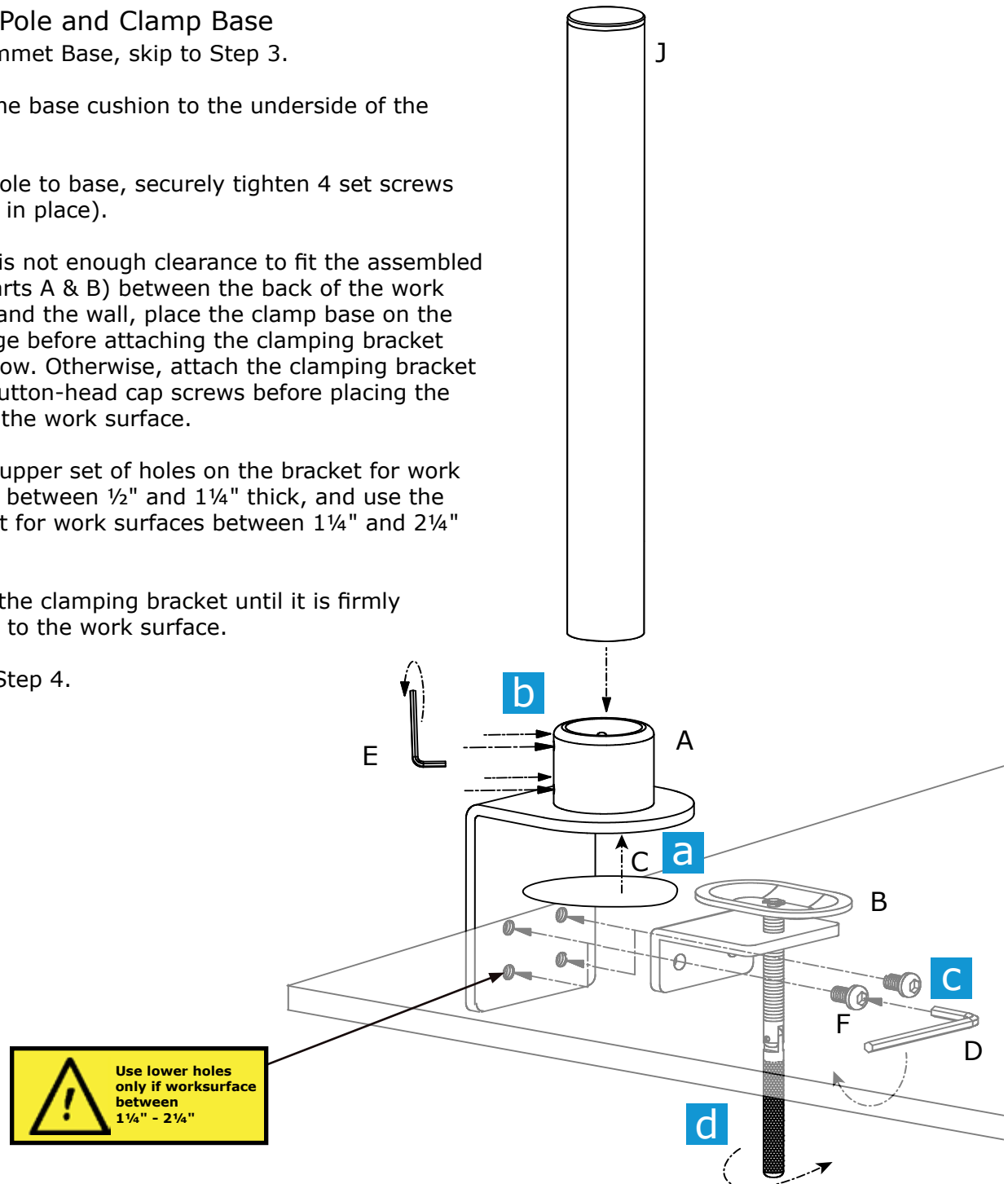

### 3 Install Pole and Grommet Base

- a** Remove center hole from base cushion, then attach to underside of base, aligning hole in base with hole in protector.
- b** Thread M8 Thread Rod into bottom of base as far as it will go.
- c** Attach pole to base, securely tighten 4 set screws (already in place).

Place base on work surface, centering it over a bolting hole from 3/8" to 3" in diameter.

- d** Position U-Bracket and Small Washer onto M8 Thread Rod and secure bracket by tightening Wing Nut.
- e** Optional (for added strength): Thread M8 Strengthening Bolt through U-Bracket and hole in back of base and secure by tightening Wing Nut.

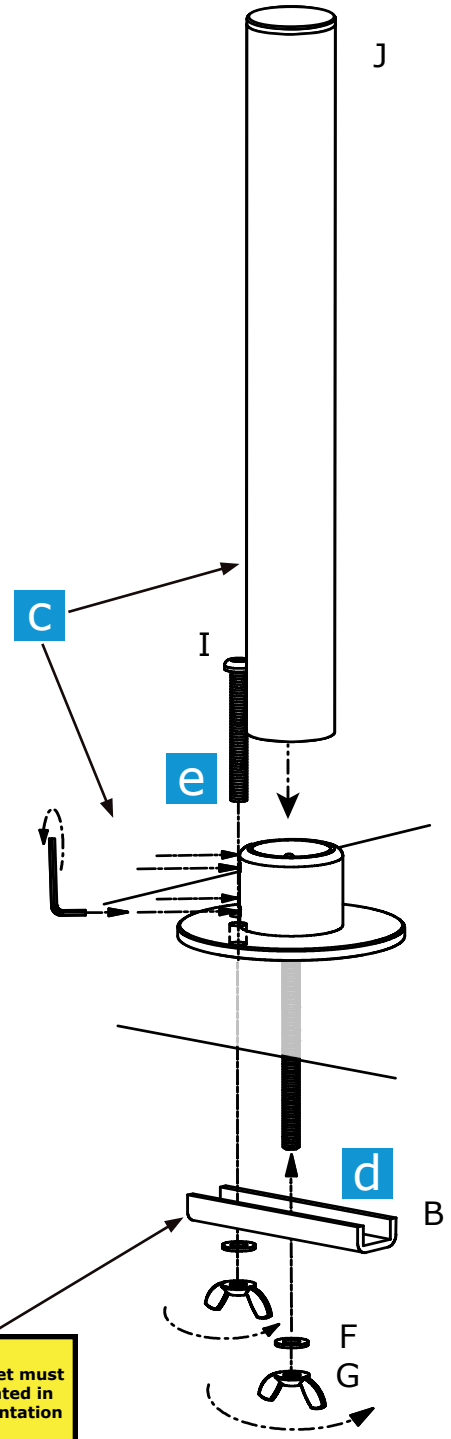
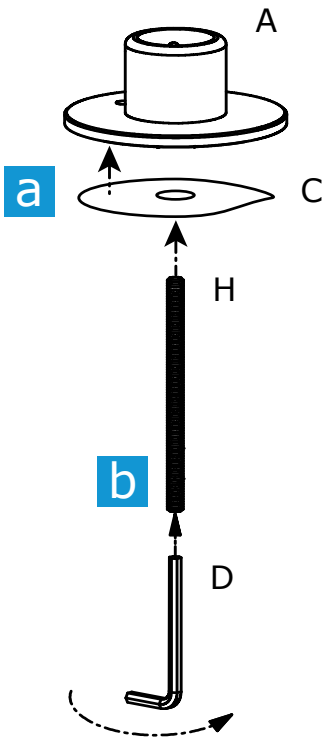

## 4 Attach Ball Joint Pivots to Monitors

Place monitor carefully on a clean, flat surface, face down.

Attach the Monitor Pivot to the back of the monitor with four screws, using a Phillips-head screwdriver (not included). Use the mounting screws provided by your monitor manufacturer if available. Otherwise, use the screws provided (parts M or N) that best fits your monitor.

If the mounting area on your monitor is smaller than the 100mm VESA connecting plate and is recessed, remove the plate and replace it with a smaller 75mm plate (sold separately). Then attach the plate to the back of the monitor.

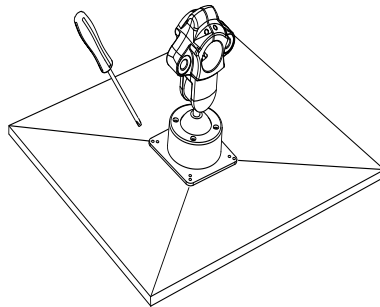

## 5 Attach Monitor

- a** Attach monitor to pole by placing Pole Mount (with monitor) onto pole with ratchet handle facing the back. See below to approximate best initial vertical position when mounting dual monitors.
- b** Tighten assembly using ratcheting handle. Pull handle out to release and rotate to allow for additional turns to tighten.

Position monitor horizontally and test height range to be sure it is correct for your monitor. If not, loosen it and move monitor assembly accordingly. Tighten securely.

Repeat for second monitor if provided.

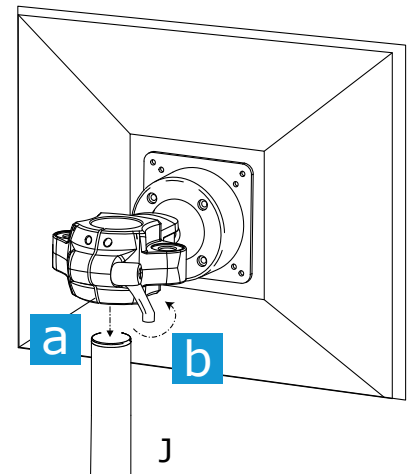

### For Bottom Monitor

Position the pivot so that the top of it is the distance shown from the desk, based on monitor size.

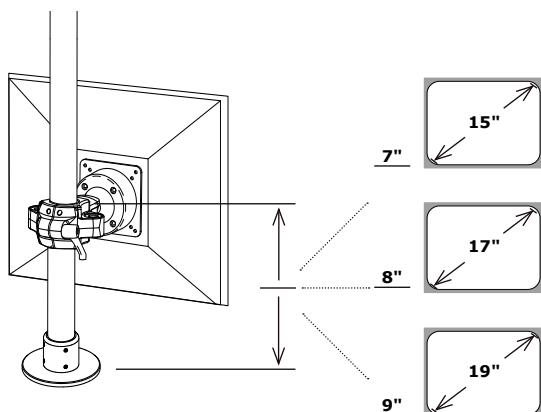

### For Top Monitor

Position the pivot so that the top of it is the distance shown from the top of the lower pivot, based on monitor size.

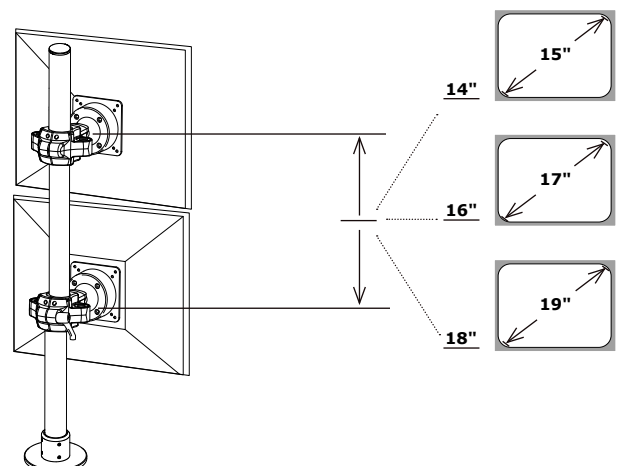

## 6 Ball-joint Adjustment for Tilt Action

- a If monitor is too tight or too loose on ball-joint, adjust tension by turning four screws closest to the ball one quarter turn each, clockwise to tighten or counterclockwise to loosen.

Repeat as necessary.

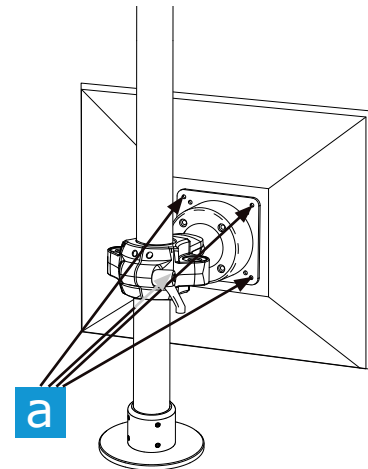
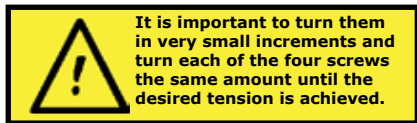

## 7 Secure the Cables

- a Attach monitor cables to Pole and secure with hook-and-loop strips.

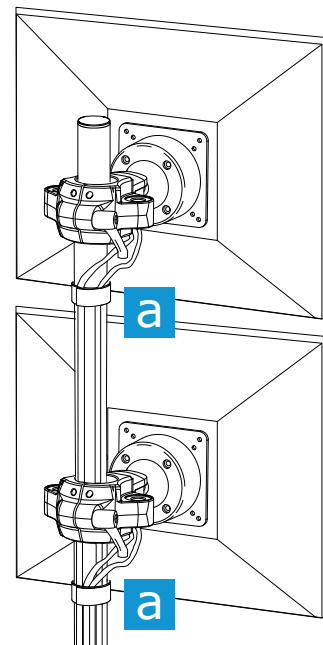

## Replacement Part Numbers

### Mounting Kits

- SACB-B: .....Clamp Base Kit
- SAGB-B: .....Grommet Base Kit

### Poles

- SALP-B: .....28" Pole

### Pivots

- SACP-B: .....Center Mount - attaches to Pole

### Miscellaneous:

- SAVS-75: .....75mm VESA Mounting Plate for recessed mount
- 4400223: .....Hardware Kit — small parts and hardware