



Sonoma Series™ VALUE

Assembly Instructions
for Tables with Right Front Crank

Parts for 3-leg tables, grouped by carton

A Tabletop (size and shape differ for each model)
Qty: 1

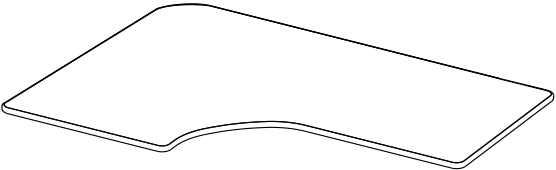

For assembly of two-piece tops, please refer to separate instructions.

B Leg 1: Right Leg
Qty: 1

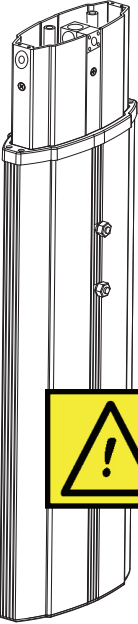

C Leg 2: Center Leg
Qty: 1

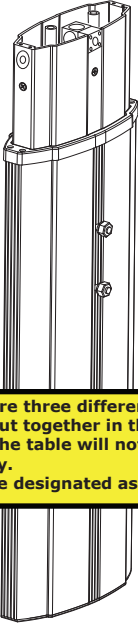

D Leg 3: Left Leg
Qty: 1

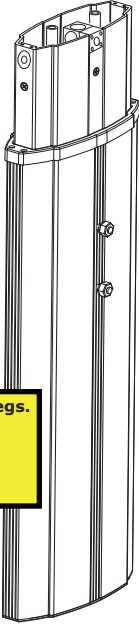



There are three different Value legs. If not put together in the correct order, the table will not function properly. Legs are designated as 1, 2 or 3.

E Side Leg Feet
Qty: 2

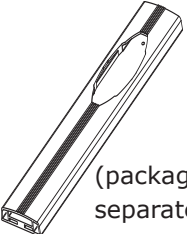

(packaged separately)

F Center Leg Foot
Qty: 1

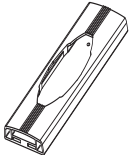

G Crossbars
Qty: 2 (packaged in pairs)



H Crank Tubes
Qty: 2



I Side Leg Top Brackets
Qty: 2

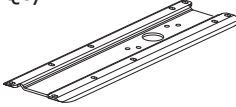

J Center Leg Top Bracket
Qty: 1



K Foot caps
Qty: 6



L Leveling Glides
Qty: 6



M Side Entry Hex Shafts
Qty: 2



N Crank Handle Hex Shaft
Qty: 1



O Front Entry Hex Shaft
Qty: 1



P Crossbar Brackets
Qty: 2

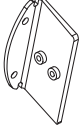

Q Center Leg Z-Bend Bracket
Qty: 1

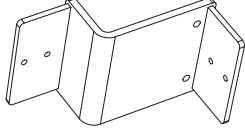

R Crank Handle Assembly
Qty: 1

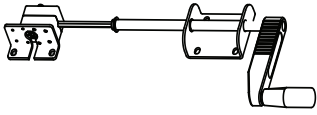

S 3/4" Button head Machine Screws
Qty: 20



T 3/4" Lock Washers
Qty: 20



U 5/32" Allen Wrench
Qty: 1



V #12 x 3/4" Wood Screws
Qty: 30



Parts for 2-leg tables, grouped by carton

A Tabletop (size and shape differ for each model)
Qty: 1

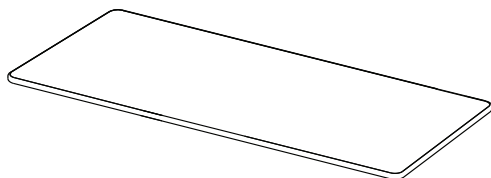

B Leg 1: Right Leg
Qty: 1

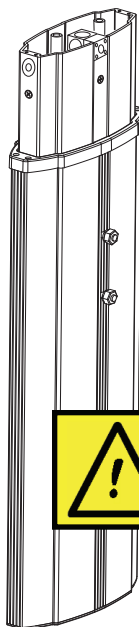

C Leg 2: Left Leg
Qty: 1

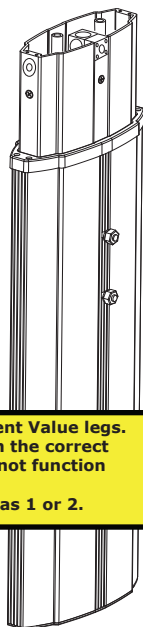

! There are two different Value legs. If not put together in the correct order, the table will not function properly. Legs are designated as 1 or 2.

E Leg Feet
Qty: 2

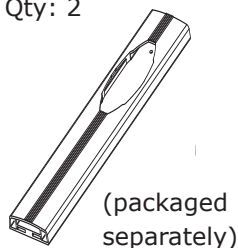

G Crossbar
Qty: 1

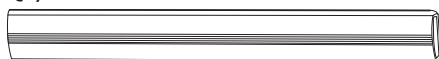

H Crank Tube
Qty: 1



I Leg Top Brackets
Qty: 2

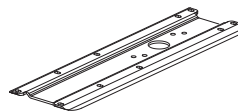

K Foot caps
Qty: 4



L Leveling Glides
Qty: 4



M Side Entry Hex Shaft
Qty: 1



N Crank Handle Hex Shaft
Qty: 1



P Crossbar Brackets
Qty: 2



W Stiffener Brackets
Qty: 2

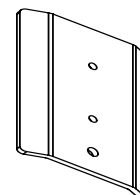

R Crank Handle Assembly
Qty: 1

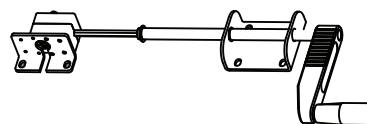

S 3/4" Button head Machine Screws
Qty: 12



T 3/4" Lock Washers
Qty: 12



U 5/32" Allen Wrench
Qty: 1



V #12 x 3/4" Wood Screws
Qty: 26



1 Verify that you have all hardware and tools needed for table assembly

Check your cartons against the list on page 2 or 3 to verify that you have all the parts needed.

You will also need the following tools:

#2 tip Phillips screwdriver

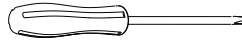

or



and

7/16" combination wrench



2 Identify the legs and their orientation

Examine top of each leg to determine leg number.

Arrange legs as shown in diagram.

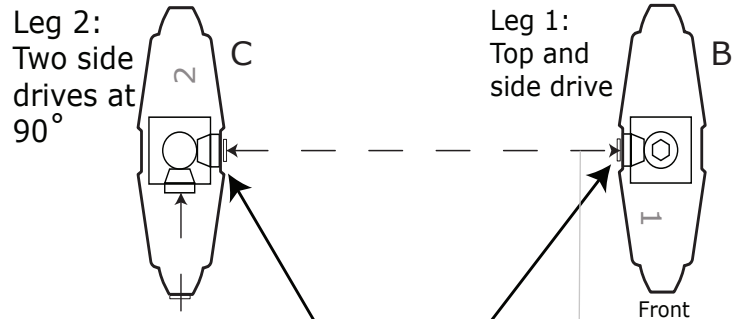
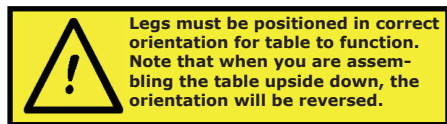

Side of leg with pre-installed nut and lock washer

To identify the leg number, look inside the top of the legs and you will see a number marking (1, 2 or 3) on the bracket. Legs can also be determined by their gear mechanisms as follows:

Leg 1:
Top and side drive



Leg 2:
Two side drives at 90°



Leg 3:
Straight through side drive

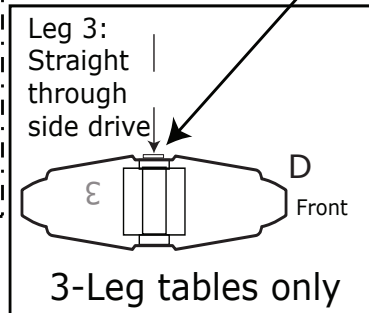

Top view when legs are right side up

3 Attach Top Brackets to Legs (repeat for each leg)

Attach Top Bracket to smallest end of each leg using two Button head Machine Screws and Lock Washers for each leg.

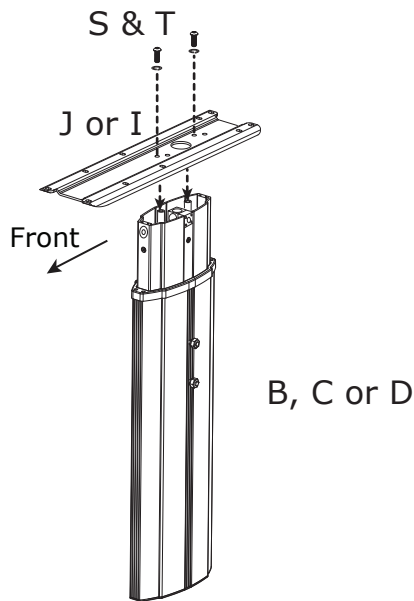

4 Attach Feet (repeat for each leg)

a Remove and discard silver transit screws securing plates to bottom of legs.

DO NOT REMOVE CENTER SCREW OR PLATE.

b Insert Foot Caps into ends of each Foot.

Screw in Leveling Glides.

Slide feet onto legs and attach with two Button head Machine Screws and Lock Washers.

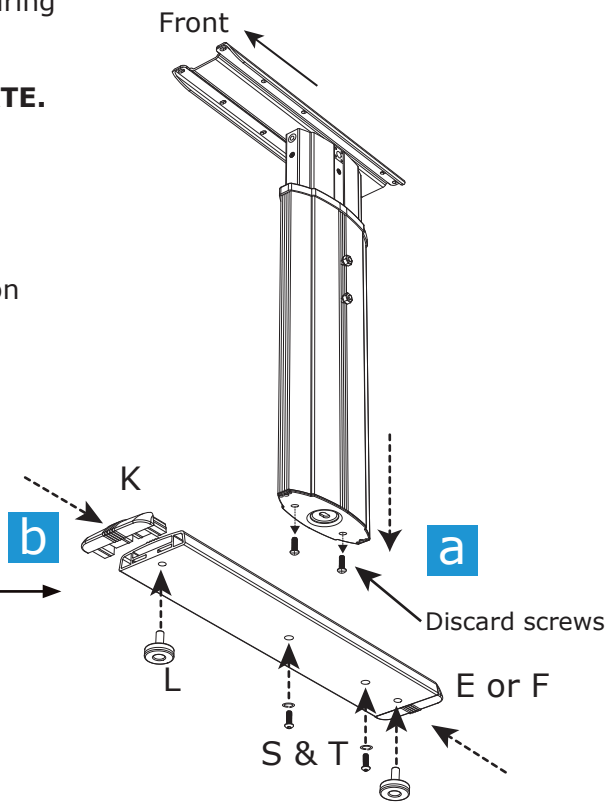

For 2-Leg Tables, proceed to step 8.

5 For 3-Leg Tables: Attach Crossbar Brackets

Turn legs upside down.

- a Remove nuts and lock washers from leg studs.
- b Slide Crossbar Brackets onto studs and reinstall nuts and lock washers. Note how the flange orients to the leg.

a

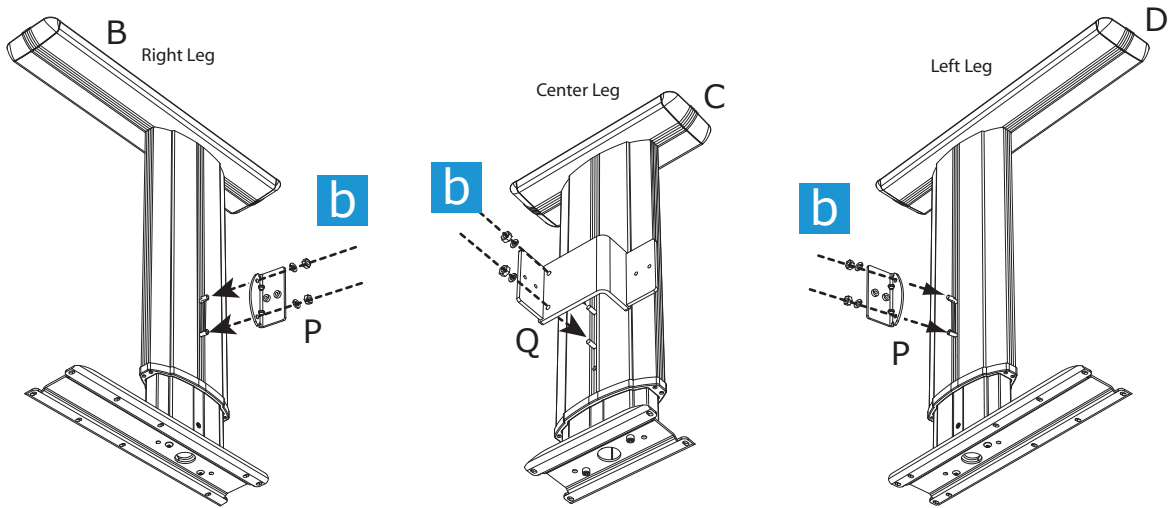
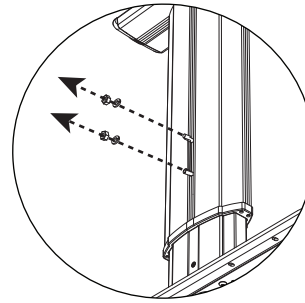

6 For 3-Leg Tables: Secure Center Leg to Table For base-only products, proceed to step 7.

Attach Leg 2 (center leg) to table using four Wood Screws provided. Use locating holes. If you use an electric screwdriver, be sure it is on the lowest torque setting to avoid stripping the threads.

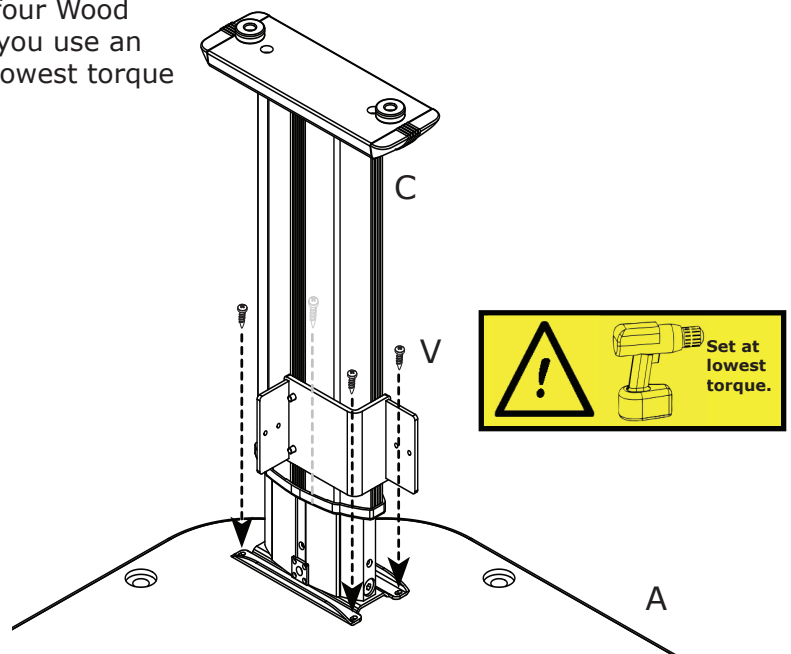

7 For 3-Leg Tables: Attach Crank Tubes and Crossbars to Leg 2

- a** Use Front Entry Hex Shaft to connect Crank Tube to gear mechanism in side of leg pointing to Leg 3 (left leg).
- b** Use Side Entry Hex Shaft to connect Crank Tube to gear mechanism in other side of leg 2. See diagram for correct placement and orientation.
- c** Slide Crossbars over Leg Brackets on Leg 2 and secure using two Lock Washers and Button head Machine Screws for each Crossbar.

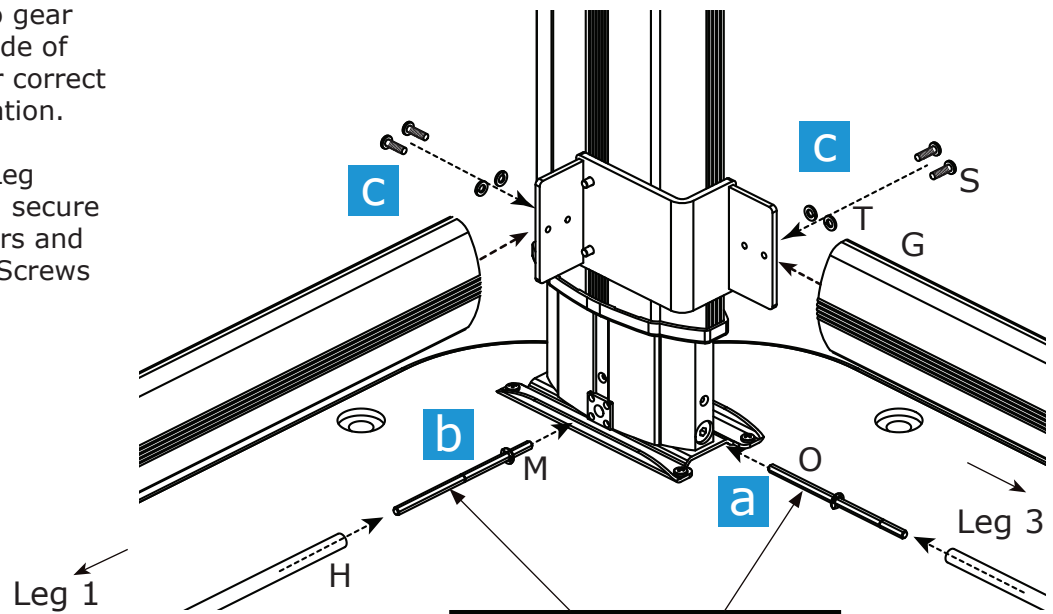

! Be sure to use the correct hex shaft inserted in the proper orientation or the table will not function.

For 3-Leg Tables, proceed to step 9.

8 For 2-Leg Tables: Attach Stiffener and Crossbar Brackets to Legs (repeat for both legs)

Turn legs upside down.

- a** Remove nuts and lock washers from leg studs.
- b** Slide Stiffener Bracket onto studs with concave side facing the leg.
- c** Slide Crossbar Brackets onto studs and reinstall nuts (but not lock washers). Note how the flange orients to the leg.

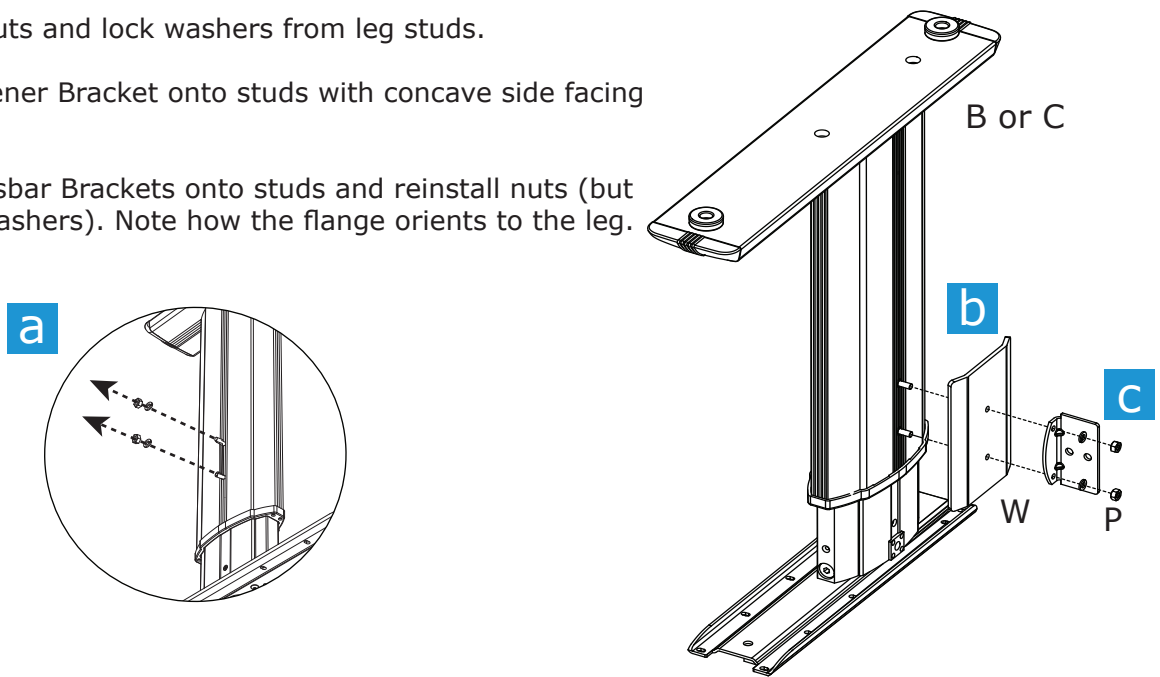

9 Attach Left Leg to Crank Tube, Crossbar and Table

- a Use second Side Entry Hex Shaft to connect Left Leg to Crank Tube, inserting short end of shaft into leg and long end into Crank Tube.
- b Slide Crossbar over Crossbar Bracket on Left Leg and secure using two Lock Washers and Button head Machine Screws.
- c For base-only version, proceed to step 10.

Attach top plate of Leg to desk using 10 Wood Screws provided. Use the locating holes. If you use an electric screwdriver, be sure it is on the lowest torque setting to avoid stripping the threads.

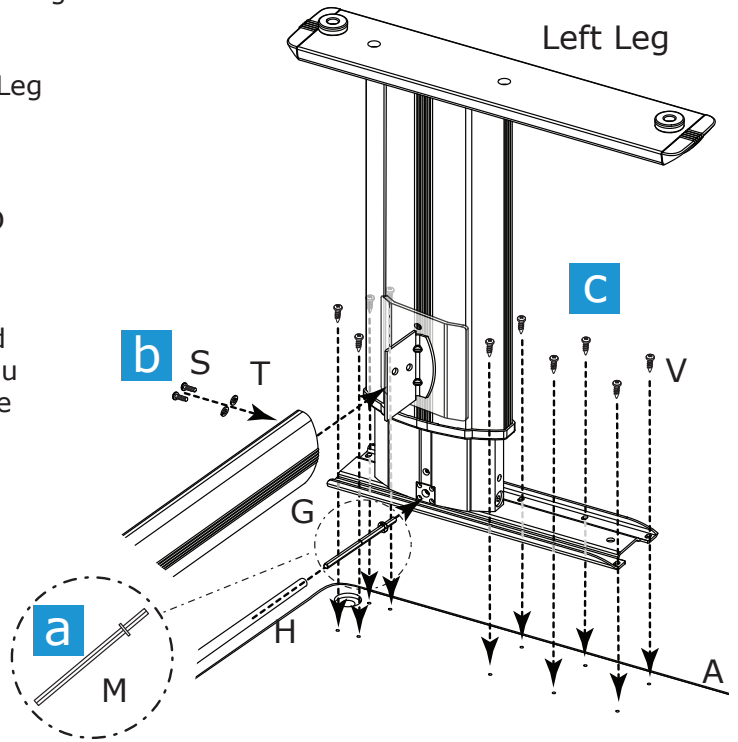
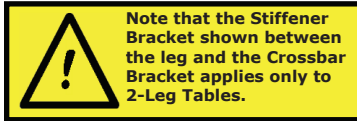

10 Attach and Connect Right Leg (Leg 1) and Crank Handle

- a Attach Crank Handle Assembly to Crank Tube, using Crank Handle Hex Shaft. Insert short end into leg and long end through Crank Handle Assembly and into Crank Tube.
- b Slide Crossbar over Leg Bracket on Leg 1 and secure using two Lock Washers and Button head Machine Screws.

For base-only version, proceed to step 11.

- c Attach top plate of Leg 1 to desk using 10 Wood Screws provided. Use locating holes. If you use an electric screwdriver, be sure it is on the lowest torque setting to avoid stripping the threads.
- d Attach Crank Handle Assembly to desk using remaining 6 Wood Screws, **but do not tighten them at this point.**

Gently pull out the handle and test that it will clear the table so that it can be rotated.

If you have a Workrite Tabletop, proceed to step 12.

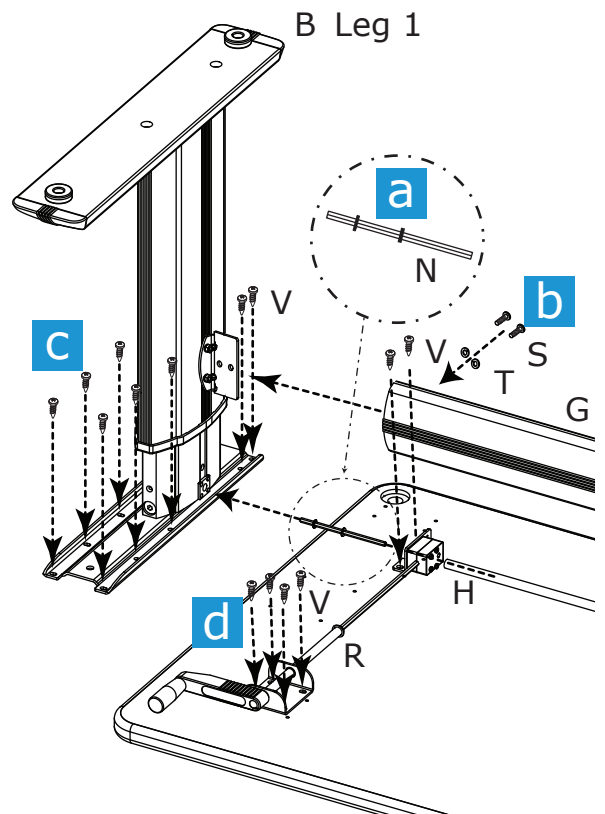

11 For Base-Only version: Secure Table Base to Tabletop

Position the leg assembly on the face-down table top. Center the assembly on the table so that neither of the side legs overlap the edge. Mark the first two pilot holes to ensure that your table will be positioned correctly as detailed below before drilling the remaining holes.

a The front right mounting hole for the crank handle must be positioned precisely $4\frac{7}{8}$ " from the absolute edge of the table as shown in the diagram.

b The front left mounting hole for Leg 1 must be positioned precisely $10\frac{7}{8}$ " from the absolute edge of the tabletop as shown in the diagram if you have a 30" base version, or $4\frac{7}{8}$ " from the absolute edge of the table if you have a 24" base version.

Be sure there is enough clearance in front of the crank handle for crank rotation and hand clearance.

c Drill and insert screws for these two holes first, then use the other screw holes to mark the location of the remaining 28 holes. Attach the desk at all points, but **do not tighten the screws that attach the crank handle at this time.**

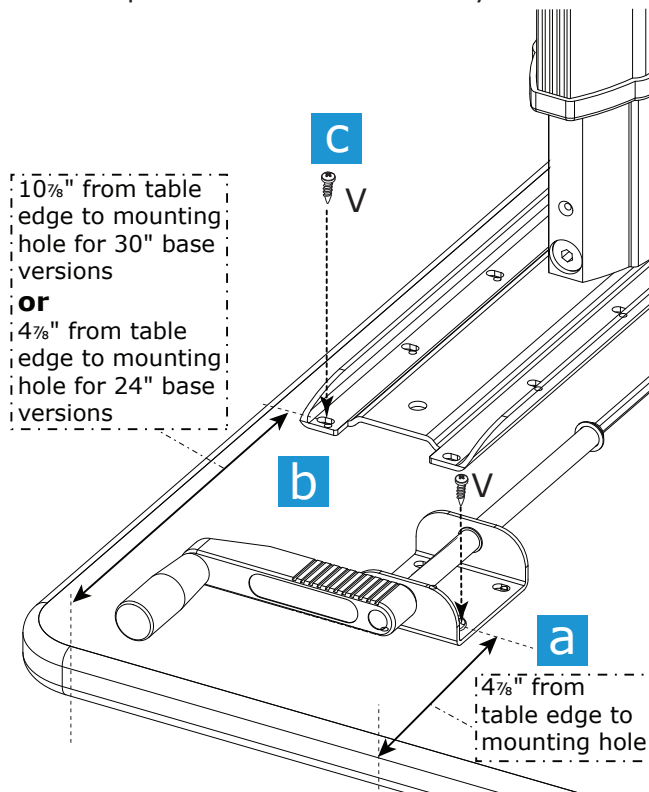

12 Tighten Crank Handle to Desk

a Push Crank Handle Assembly as close to leg as possible, ensuring clips on hex rod are flush against leg and gear box.

b While pushing on crank assembly, tighten Wood Screws connecting bracket to desk.

c Tighten screws connecting handle to desk.

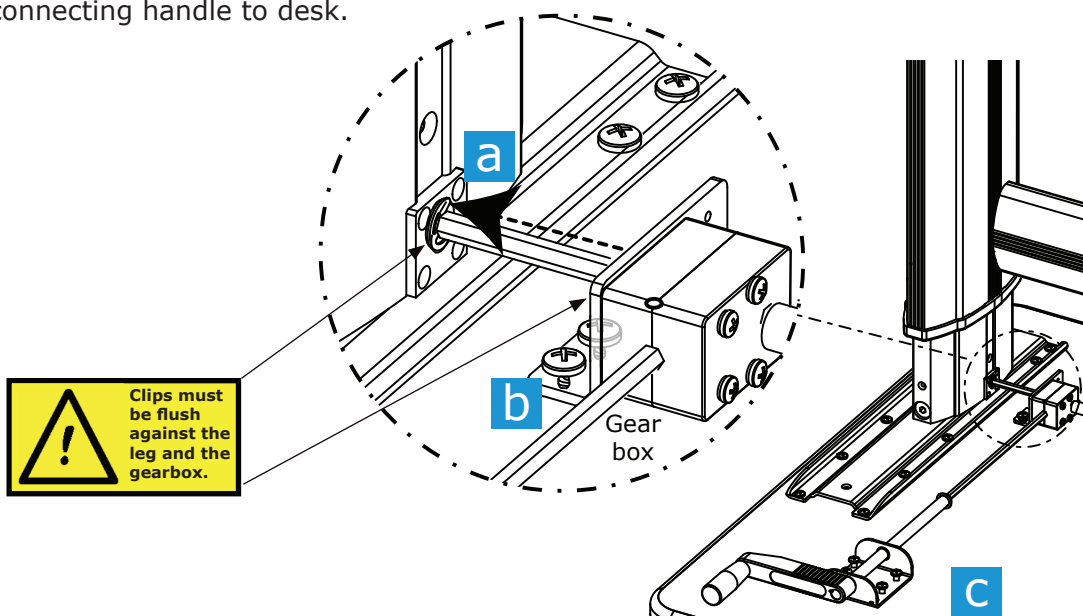

13 Final Step

Flip table over and adjust Leveling Glides if required so that table is steady and does not rock.

Pull out and turn handle to raise or lower table.

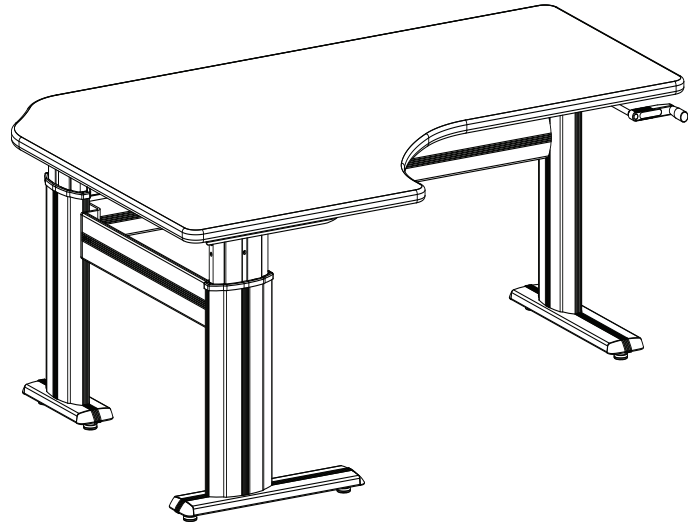
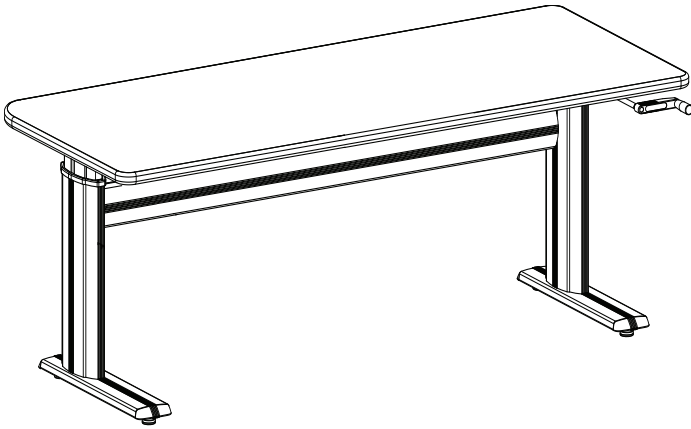

Replacement Part Numbers

Center Leg Crossbar (Z-Bend) Bracket	5513915 ¹	
Center Leg Foot - Graphite.....	6400264 ¹	
Silver	6400263 ¹	
Center Leg Top Bracket	5512974 ¹	
Crank Handle Assembly	6100078	
Crank Tube	6000004-xx.xxx"	(consult factory for length)
Crossbar - Graphite	6000002-xx"	(consult factory for length)
Silver	6000001-xx"	(consult factory for length)
Foot Cap	3500088	
Hardware Kit.....	4200101	(all screws and washers, and Allen wrench)
Hex Shaft Kit	4206668	
Leg 1 - Graphite.....	6500006	
Silver	6500005	
Leg 2 - Graphite.....	6500008	
Silver.....	6500007	
Leg 3 - Graphite.....	6500010 ¹	
Silver.....	6500009 ¹	
Leveling Glide	3300252	
Side Leg Crossbar Bracket	5512863	
Side Leg Foot (20") - Graphite.....	6400266	
Silver	6400265	
Side Leg Top Bracket.....	5512972	
Stiffener Bracket - Graphite	5500104-02 ²	
Silver	5500104-01 ²	

¹ - Applies to 3-Leg Tables only

² - Applies to 2-Leg Tables only