



Sierra™ Electric

---

Assembly Instructions  
for 2 and 3-leg Workcenters

# List of Parts, grouped by carton

**A** Top (size and shape differ for each model)  
Qty: 1

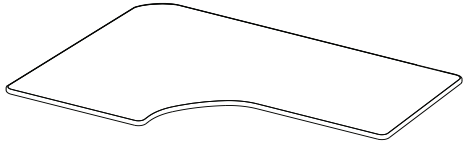

For assembly of two-piece tops, please refer to separate instructions.

**B** Side Leg with feet and top bracket  
Qty: 1

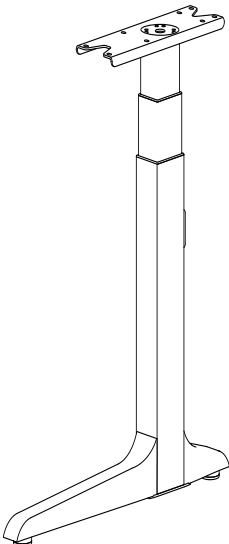

**C** Center Leg with glide support, top bracket and crossbar bracket  
Qty: 1  
**3-Leg Tables Only**

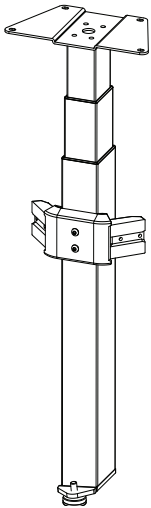

**D** Crossbars  
Qty: 1 or 2 as shown

**2-Leg:** Qty: 1

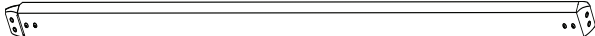

**3-Leg:** Qty: 2

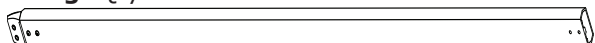

**E** 1/4-20 x 5/8" Button head Machine Screws  
**2-Leg:** Qty: 4; **3-Leg:** Qty: 8



**F** 5/32" Allen Wrench  
Qty: 1 per crossbar



**G** Control Box  
Qty: 1

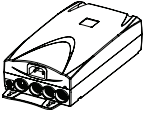

**H** #8 x 5/8" Mounting Screws  
Qty: 4



**I** Switch with 2 mounting screws: #8 x 1 1/8" Machine Screws or #8 x 3/4" Phillips head Screws  
Qty: 1

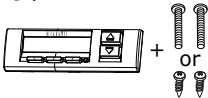

**J** #12 x 3/4" Phillips head Screws  
Qty: 20



**K** Cable management kits  
Qty: 2 or 3

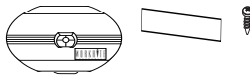

**L** Power cord  
Qty: 1

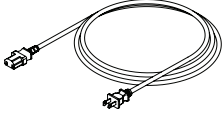

**M** Extension Cable  
Qty: 1 or 2 if needed  
(supplied only with large 3-leg workcenters)



**N** User Guide  
Qty: 1



**B** Side Leg with feet and top bracket  
Qty: 1

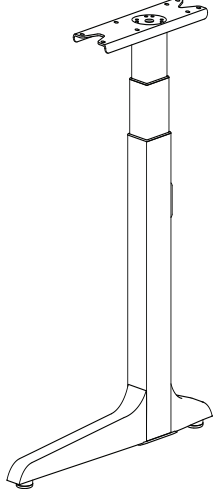

**Important Note**  

 You must complete initialization (Steps 12 - 13) at the end of assembly or your table WILL NOT FUNCTION PROPERLY.

**1**

Verify that you have all the hardware and tools needed for the assembly

Check your cartons against the list on page 2 to verify that you have all the parts needed.

You will also need the following tools:

- #2 tip Phillips screwdriver or drill bit
- #3 tip Phillips screwdriver or drill bit

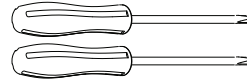

or

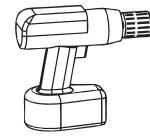

If you do not have a WorkRite tabletop, you will also need a:

- 1/8" pilot drill bit



**2**

3-Leg Tables Only: Attach Crossbars to Center Leg Bracket using 1/4-20 x 5/8" Button head Machine Screws and 5/32" Allen Wrench

For 2-Leg table assembly, please proceed to Step 3.

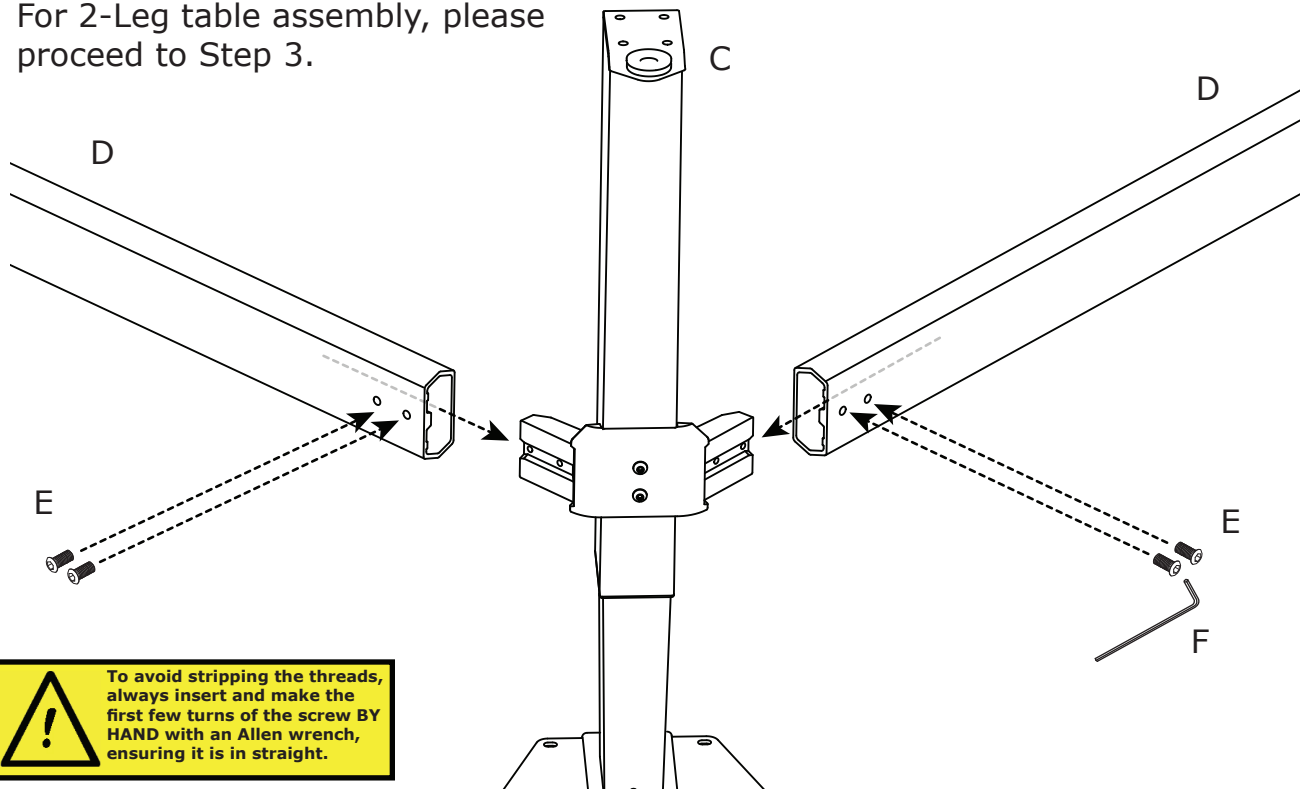

**!** To avoid stripping the threads, always insert and make the first few turns of the screw BY HAND with an Allen wrench, ensuring it is in straight.

### 3 Attach Crossbars to Side Legs using 1/4-20 x 5/8" Button head Machine Screws

3-Leg Tables

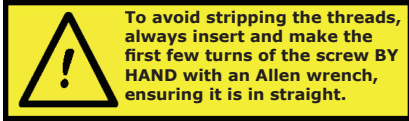
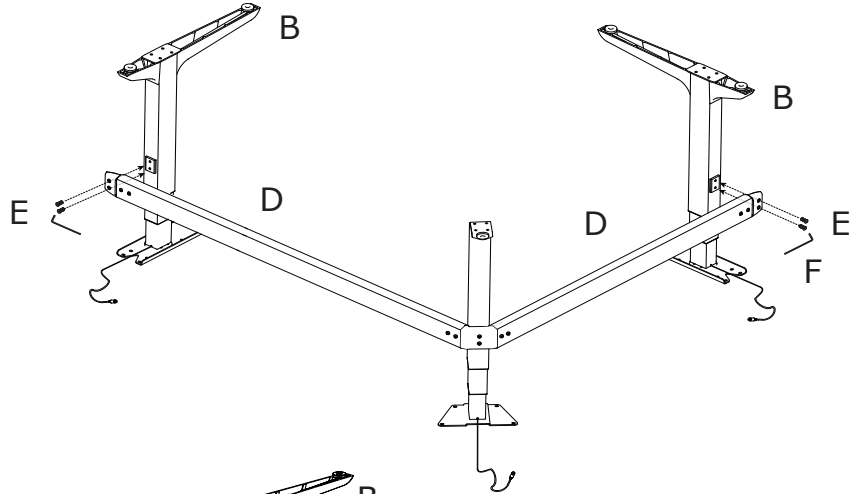

2-Leg Tables

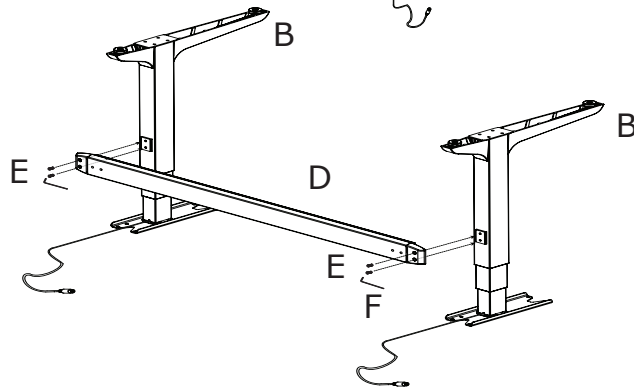

### 4 Attach Base to Tabletop

If you have a WorkRite tabletop, align top bracket mounting holes to pre-drilled holes in tabletop and attach using #12 Phillips head Screws.

Otherwise, align base in desired position and mark placement of mounting holes, then use drill bit to drill pilot holes at marked locations. Do not drill all the way through tabletop! Attach to the base using #12 Phillips head Screws.

3-Leg Tables

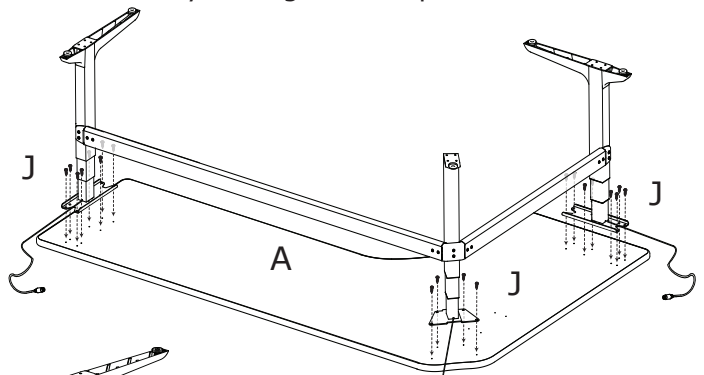
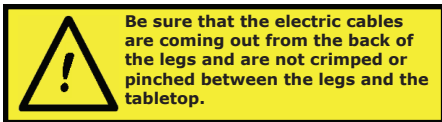

2-Leg Tables

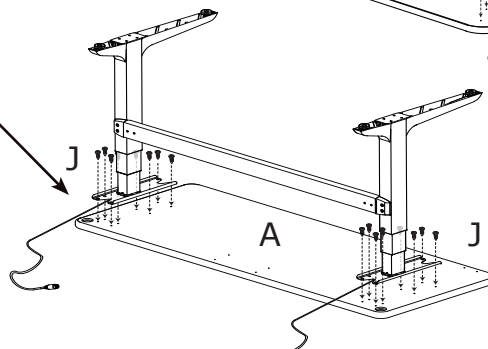

## 5 Attach Control Box to Tabletop

### If you do not have a WorkRite tabletop:

Place Control Box in position and use a pencil to mark pilot hole placement. Control box should be placed towards rear center of tabletop. Be sure to place marks in the **small** part of Mounting Flange's keyhole openings. Remove Control Box and drill pilot holes where marked.

**a** With Control Box positioned over pilot holes, attach two #8 x 5/8" Mounting Screws through the small part of Mounting Flange's keyhole openings.

**b** Attach two #8 x 5/8" Mounting Screws through Mounting Tab at back of Control Box.

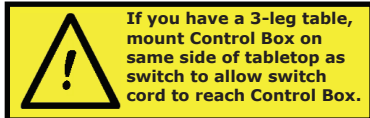
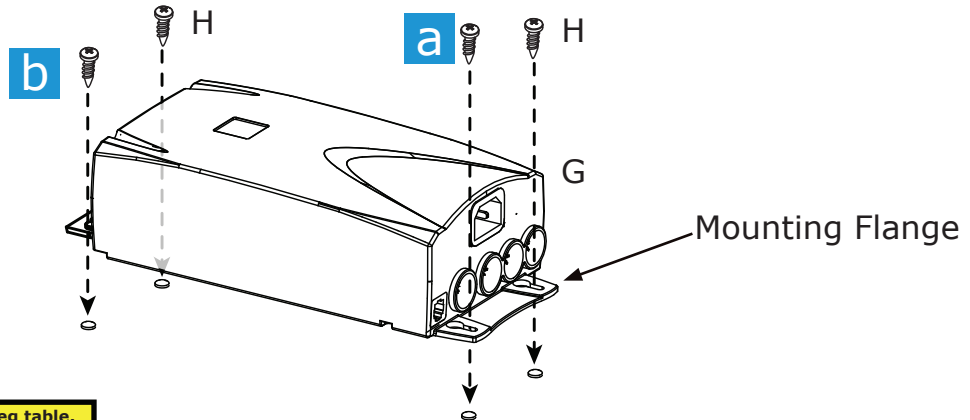

## 6 Attach Cable Spools and Velcro Tabs

Attach cable spools and Velcro® tabs to underside of tabletop as indicated in instructions contained within Cable Management Kit. If you do NOT have a WorkRite tabletop, mount cable spools in a convenient location between legs and control box.

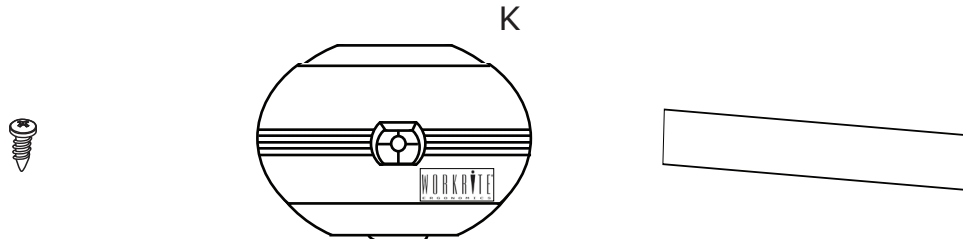

Refer to instructions in Cable Management Kit.

## 7 Attach Switch

If you have an under worksurface switch, please proceed to Step 9b below.

### a On Worksurface Switch

Tilt table so that you can access both sides of tabletop. Attach on worksurface switch by inserting the switch into the recessed opening. Attach back plate with screws provided with switch. Proceed to Step 10.

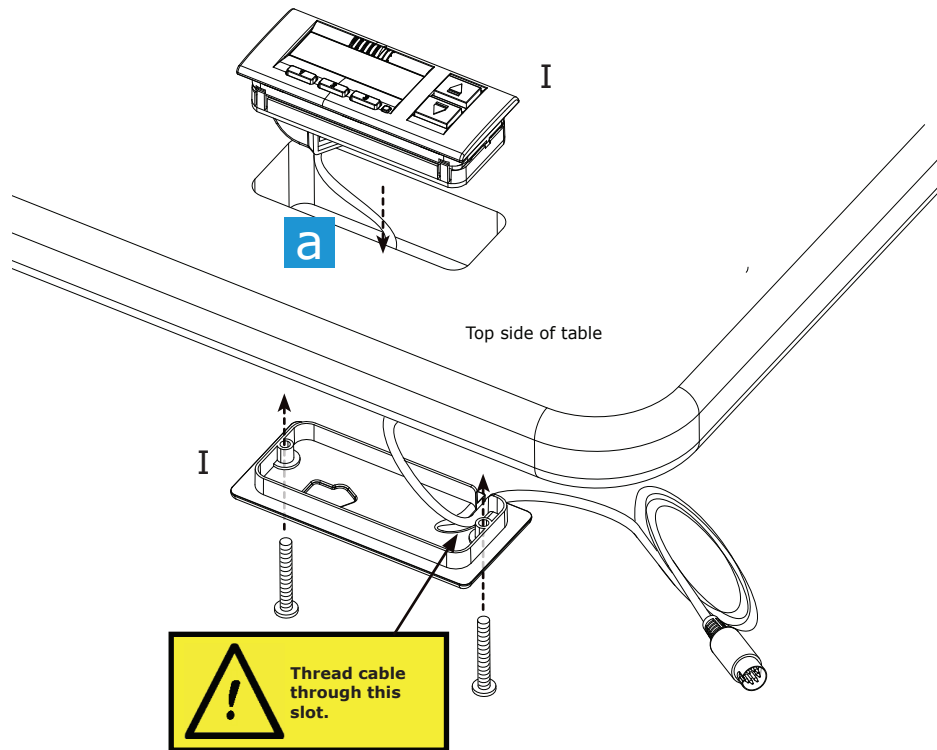

**OR**

### b Under Worksurface Switch

Attach under worksurface switch to underside of tabletop using screws provided with switch. WorkRite tabletops will have pilot holes near front edge of tabletop.

If installing on non-WorkRite tabletop, align switch so that outermost edge of switch is flush with edge of tabletop. Pre-drill screw pilot holes with  $\frac{3}{32}$ " drill bit. Attach under worksurface switch to underside of tabletop using screws provided with switch.

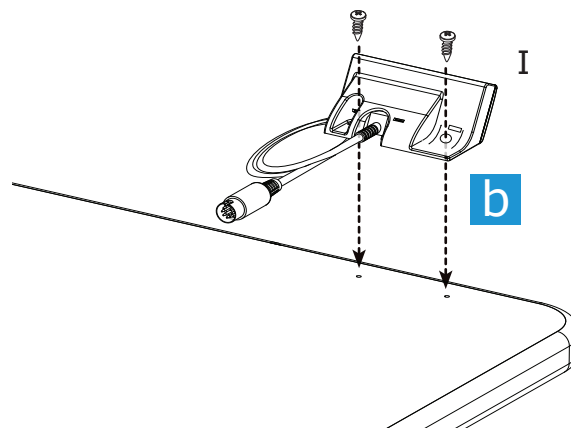

## 8 Connect Leg Cables to Control Box

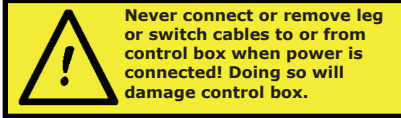

- a** If provided, use extension cable(s) for the leg(s) farthest from the control box.
- b** Insert the leg cables into the terminals labeled M1, M2 and M3. For 2-Leg tables, DO NOT USE terminal M3.
- c** Insert the **blue** switch cable into the terminal labeled HS.

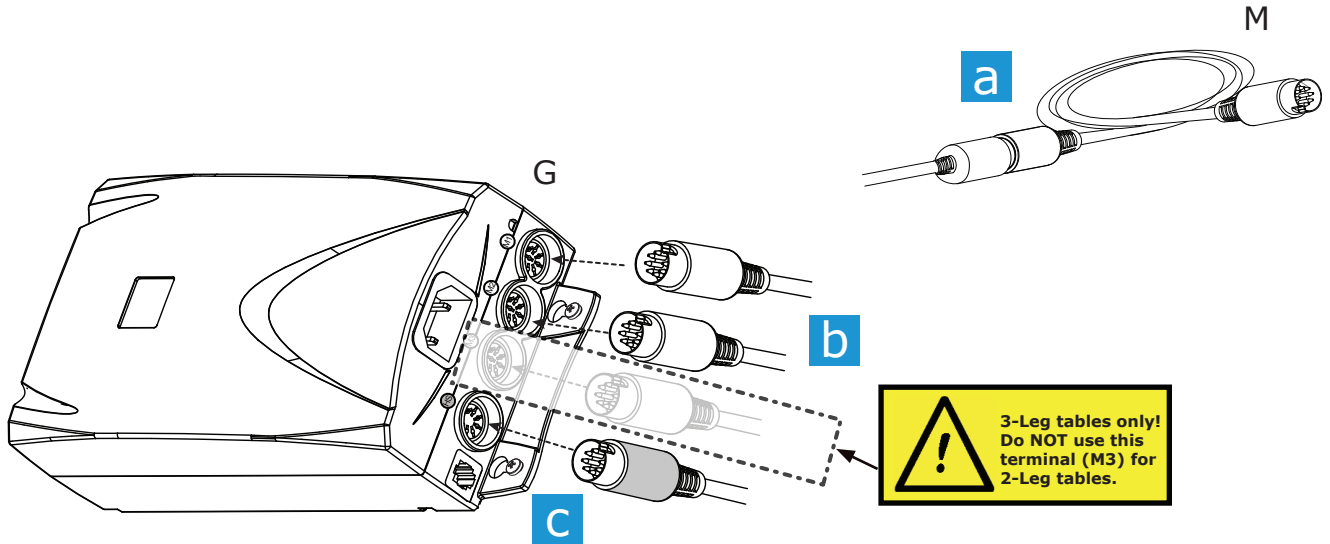

## 9 Connect Power to Control Box and put Workcenter upright

- a** Connect the electrical cable to the control box.
- b** Turn the table over into an upright position.
- c** Plug the electrical cable into the power outlet.

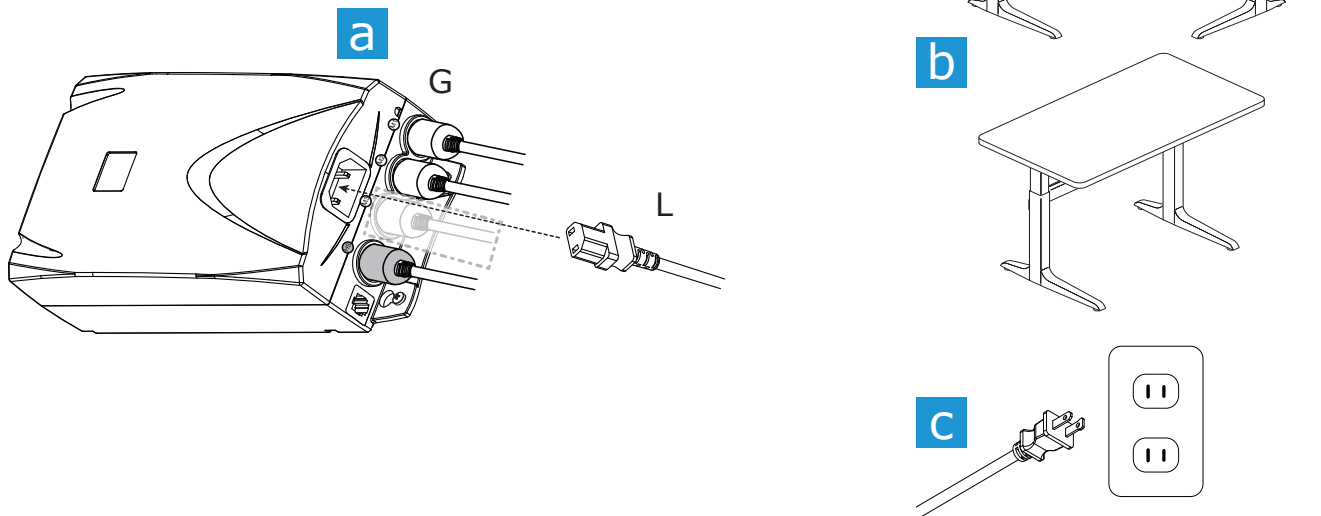

## 10 Initialize Legs

After all legs and the switch are connected, and the power cord has been plugged in, hold the **down** arrow on the switch until the legs will make a short motion down and then back up. This initializes and synchronizes the table legs.

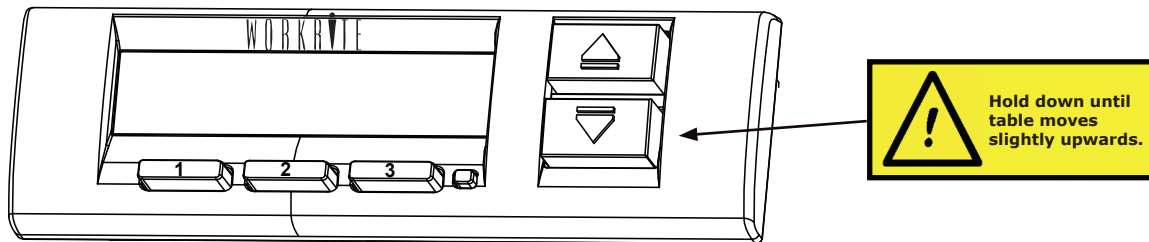

---

## 11 Adjust Leveling Guides

If necessary, adjust leveling guides on table feet to level the worksurface.

---

## 12 Verify successful assembly

### Three-leg tables:

After initialization, three-leg tables will show current height, in inches, in switch display window.

### Two-leg tables:

After initialization, two-leg tables will show code E31, indicating that a third leg is not plugged in. This is normal. Press the up button momentarily to clear code and display leg height.

### What to do if you get an error code:

Any other code appearing in the switch display window immediately after initialization indicates an error has occurred.

First, try raising the table slightly by pressing the up arrow briefly - this may be all it takes to clear the error.

If that does not clear the error, use the following procedure:

1. Unplug the power from the control box.
2. Reseat each of the leg cables and the switch cable into control box, making sure they are firmly connected and completely engaged.
3. For two-leg tables, be sure you are not using terminal M3 (see Step 10).
4. Plug in power cable again, and re-initialize by holding the down arrow until table moves slightly upwards.
5. Raise table legs slightly by briefly pressing the up arrow.

If you still encounter an error, please note error code (if shown) and call WorkRite Customer Service.

## 13 Install User Guide

Peel off backing and place User Guide sleeve under worksurface, adjacent to switch. Be sure that the open edge faces out.

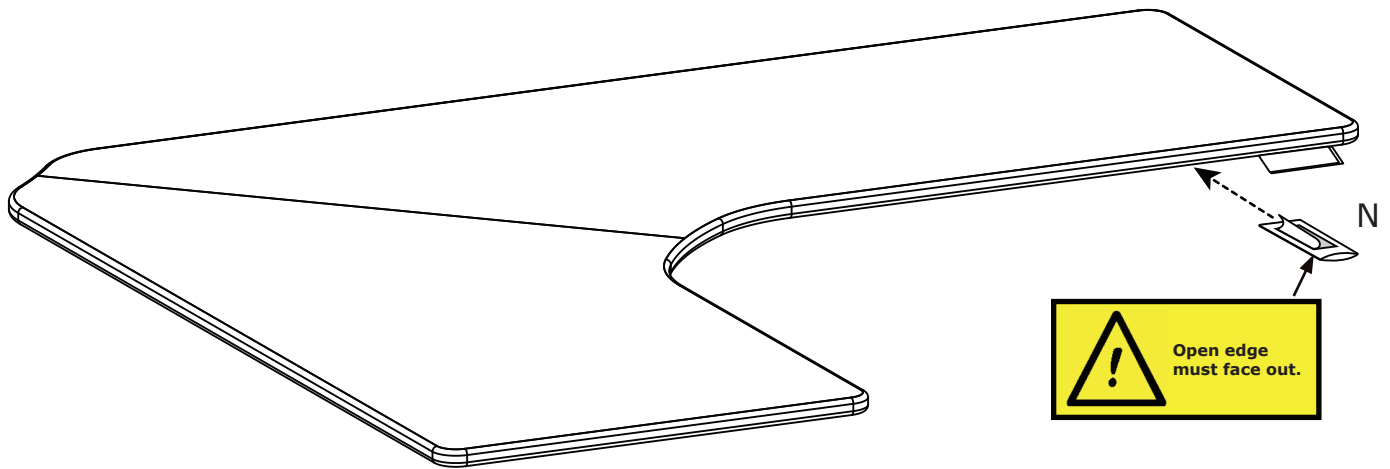

---

### Important disassembly instructions

Always remove the power from the control box before disconnecting any leg or switch cables.

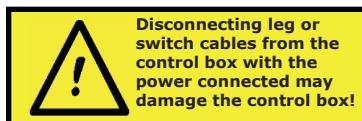

---

### Cleaning instructions

To clean the Sierra legs, simply use plain water and a soft cloth.

## Replacement Part Numbers

### Feet:

6400341-01: Sierra Foot, Short (5 $\frac{3}{8}$ " ), Sierra Silver  
6400341-02: Sierra Foot, Short (5 $\frac{3}{8}$ " ), Charcoal  
6400339-01: Sierra Foot, Medium (7 $\frac{7}{8}$ " ), Sierra Silver  
6400339-02: Sierra Foot, Medium (7 $\frac{7}{8}$ " ), Charcoal  
6400337-01: Sierra Foot, Long (14 $\frac{3}{4}$ " ), Sierra Silver  
6400337-02: Sierra Foot, Long (14 $\frac{3}{4}$ " ), Charcoal

### Legs:

6400385-01: Sierra End Leg - Sierra Silver  
6400385-02: Sierra End Leg - Charcoal  
6400386-01: Sierra Center Leg - Sierra Silver  
6400386-02: Sierra Center Leg - Charcoal  
Please call factory for assembled leg kits. (Leg assembly includes leg, bracket, feet and glides.)

### Crossbar Assemblies:

6000005-01-(YY)-2LEG: Sierra Silver Cross Bar Assembly for 2-leg workcenters  
6000005-02-(YY)-2LEG: Sierra Charcoal Cross Bar Assembly for 2-leg workcenters  
6000005-01-(YY)-3LEG: Sierra Silver Cross Bar Assembly for 3-leg workcenters  
6000005-02-(YY)-3LEG: Sierra Charcoal Cross Bar Assembly for 3-leg workcenters  
("YY" is the cross bar length in inches.)  
(All assemblies include mounting brackets and necessary screws.)

### Crossbar Components:

6400334-01: Bracket, X-bar Mount, Side, Sierra Silver  
6400334-02: Bracket, X-bar Mount, Side, Charcoal  
6400335-01: Bracket, X-bar Angled 90 Deg, Sierra Silver  
6400335-02: Bracket, X-bar Angled 90 Deg, Charcoal  
6400353-01: Bracket, X-bar Angled 120 Deg, Sierra Silver  
6400353-02: Bracket, X-bar Angled 120 Deg, Charcoal  
6000005-01-(YY): Sierra Silver Cross Bar ("YY" is length in inches) (*no mounting hardware included*)  
6000005-02-(YY): Sierra Charcoal Cross Bar ("YY" is length in inches) (*no mounting hardware included*)

### Top Brackets:

6400336: Bracket, Worksurface Mount  
6400348: Bracket, Corner, Worksurface Mount

### Switches and Controls:

6400405: Sierra Control Box  
6400392: Switch, Sierra, Under worksurface  
6400393: Switch, Sierra, On worksurface  
6400398: Extension Cable, Sierra, 1-meter  
6400399: Power Cord For Sierra Control Box

### Miscellaneous Hardware:

3300353: Screw # $\frac{1}{4}$ -20 X  $\frac{5}{8}$  Buttonhead Allen Black  
3300252: AWC Leveling Glide 1- $\frac{3}{8}$  Hank Glide  
3300085: Screw #12 X  $\frac{3}{4}$ " Pan Phillips head Zinc Sheetmetal  
3300352: Screw #8 X  $\frac{5}{8}$ " Pan Phillips head Zinc Sheetmetal  
4400139: AWC Cable Spool Wire Management Kit

### User Guide:

1500122: Sierra User Guide



# Sierra Series Workcenters Special Settings

## 1 Initialize legs if you have not done so already

After all the legs and the switch are connected *and* the power cord has been plugged in, hold the **down** arrow on the switch until the legs make a short motion down and then back up. This initializes and synchronizes the table legs.

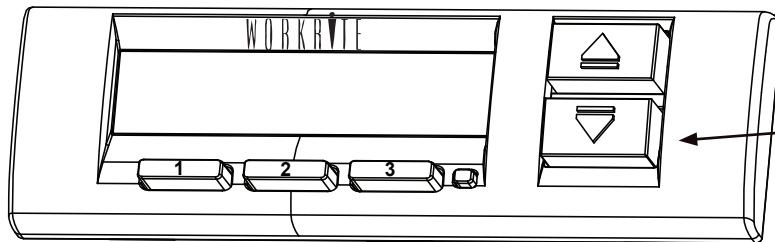

## 2 Change display from inches to centimeters

- a Simultaneously press and hold 1 & 2 and the Up Arrow until the readout changes to show "5 5".
- b Press the "SET" button with a ballpoint pen (NOT paperclip) to change from inches to centimeters.

To return to inches, repeat the same process.

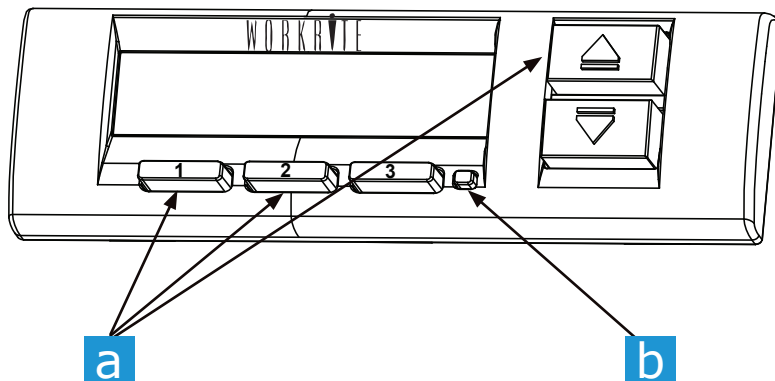

### 3 Adjust Starting Digital Height Readout

(Use if you have a worksurface that is not 1½" thick, causing inaccurate readout of the lowest height)

- a** Lower the table to the lowest position and measure the height from the floor to the top of the worksurface. (not shown)
- b** Press the "SET" button with a ballpoint pen (Do NOT use a paperclip - it may damage the electronics).
- c** Press and hold "Down" button until display flashes.
- d** Press "Up" or "Down" button until display shows actual measured height for the worksurface.
- e** Press the "SET" button with a ballpoint pen (NOT a paperclip).

Note: Height readout must be readjusted separately for inches and centimeters.

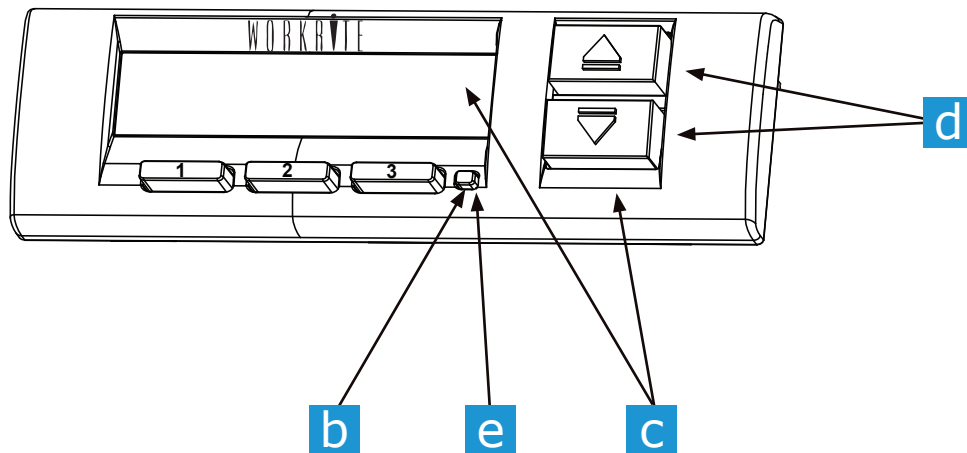

### 4 Table Locking Feature

- a** To Lock:  
Press and hold the "SET" button with a ballpoint pen until the control box clicks two times – The table will now be locked and will not move when any buttons are pushed. A padlock icon will appear on the display when the table is locked.
- b** To Unlock:  
Press 1, then 2 and then 3 to unlock. \*The default unlock code is always 1-2-3.

