



## Sierra Pin

---

# Assembly Instructions for 2 and 3-leg Workcenters

# List of Parts, grouped by carton

**A** Top (size and shape differ for each model)  
Qty: 1

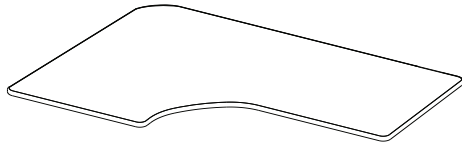

For assembly of two-piece tops, please refer to separate instructions.

**D** Crossbars  
Qty: 1 or 2 as shown

**2-Leg:** Qty: 1

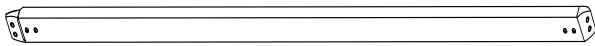

**3-Leg:** Qty: 2

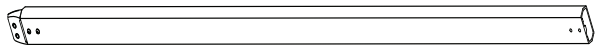

**E** 1/4-20 x 5/8" Button head Machine Screws  
**2-Leg:** Qty: 4; **3-Leg:** Qty: 8



**F** 5/32" Allen Wrench  
Qty: 1 per crossbar



**There are two Side Leg cartons for each workcenter.**

**B** Side Leg with feet and top bracket  
Qty: 1 per carton

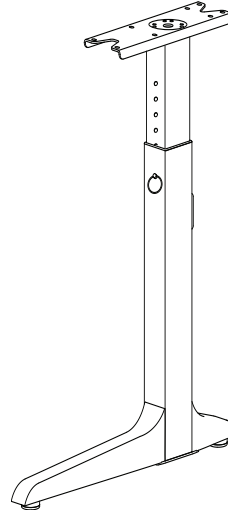

**H** Ring Pin (already installed)  
Qty: 1 per carton

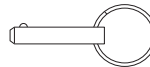

**G** #12 x 3/4" Phillips head Screws  
Qty: 8 per carton



**C** Center Leg with glide support, top bracket and crossbar bracket  
Qty: 1

**3-Leg Tables Only**

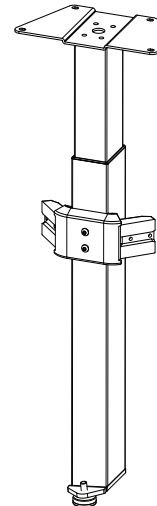

**H** Ring Pin (already installed)  
Qty: 1

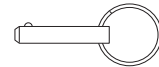

**G** #12 x 3/4" Phillips head Screws  
Qty: 4



# 1 Verify that you have all the hardware and tools needed for the assembly

Check your cartons against the list on page 2 to verify that you have all the parts needed.

You will also need the following tools:

#3 tip Phillips screwdriver or drill bit



or

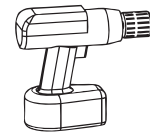

If you do not have a WorkRite tabletop, you will also need a:

1/8" pilot drill bit



## 2 3-Leg Tables Only: Attach Crossbars to Center Leg Bracket using 1/4-20 x 5/8" Button head Machine Screws and 5/32" Allen Wrench

For 2-Leg table assembly, please proceed to Step 3.

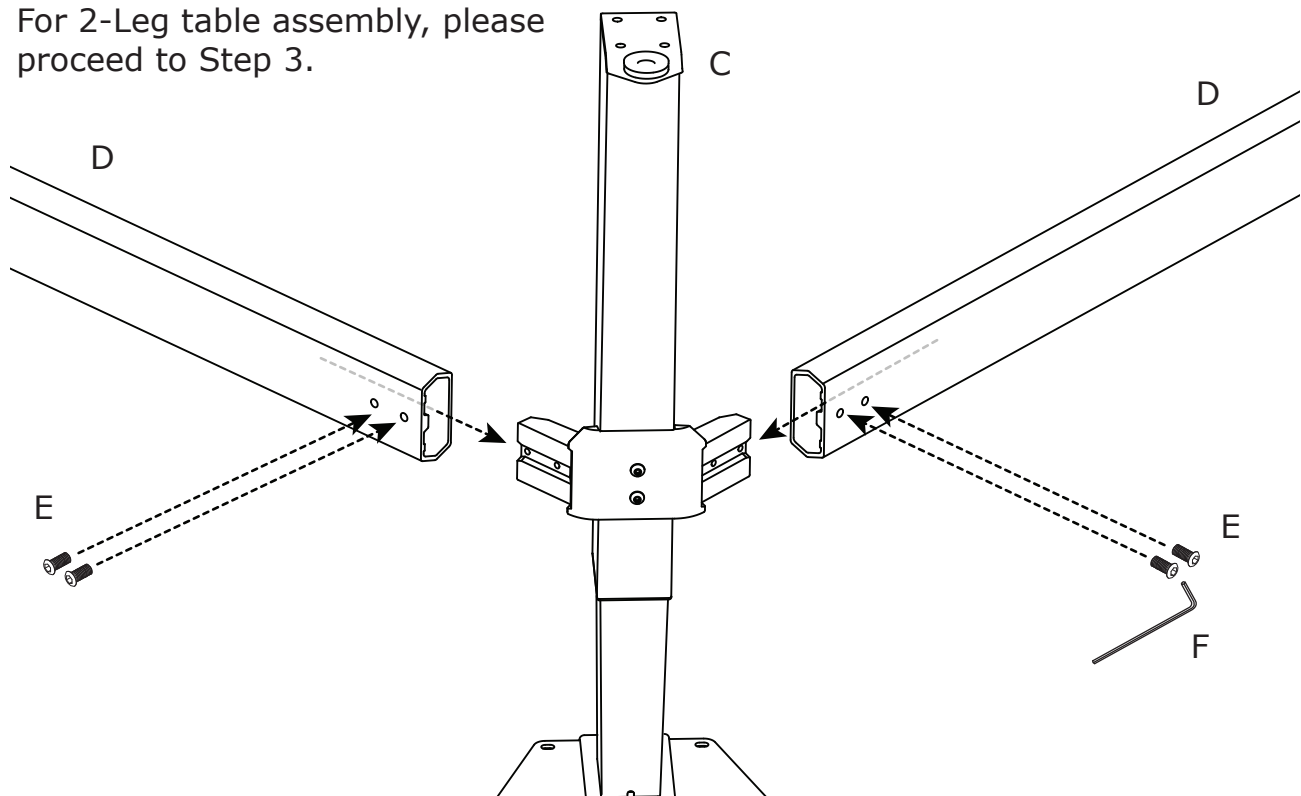



To avoid stripping the threads, always insert and make the first few turns of the screw **BY HAND** with an Allen wrench, ensuring it is in straight.

# 3

## Attach Crossbars to Side Legs using 1/4"-20 x 5/8" Button head Machine Screws

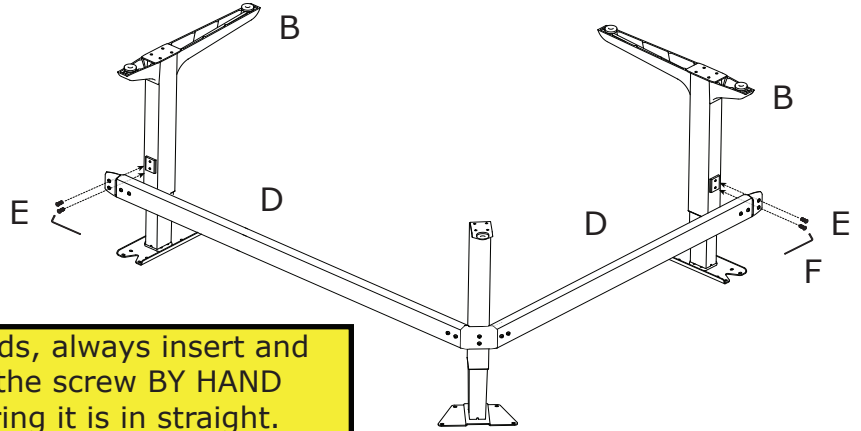
3-Leg Tables



 To avoid stripping the threads, always insert and make the first few turns of the screw **BY HAND** with an Allen wrench, ensuring it is in straight.

2-Leg Tables

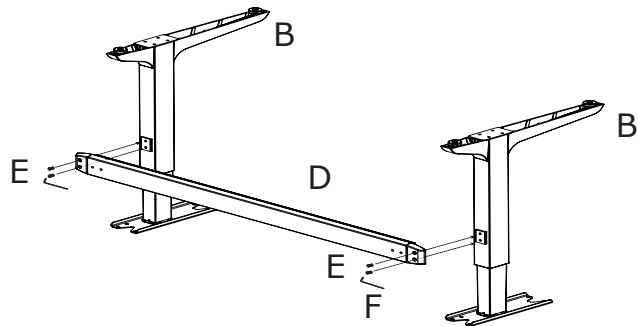

# 4

## Attach Base to Tabletop

If you have a WorkRite tabletop, align top bracket mounting holes to pre-drilled holes in tabletop and attach using #12 Phillips head Screws.

Otherwise, align base in desired position and mark placement of mounting holes, then use drill bit to drill pilot holes at marked locations. Do not drill all the way through tabletop! Attach to the base using #12 Phillips head Screws.

3-Leg Tables

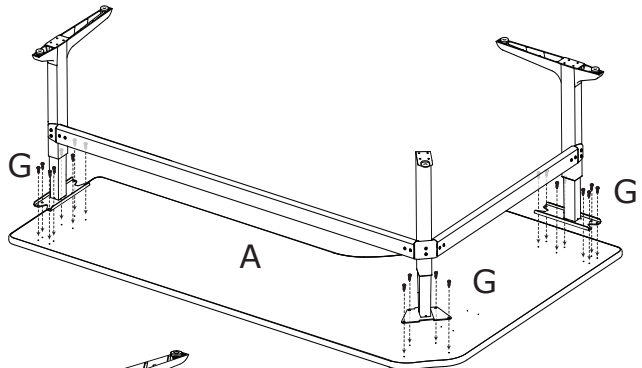

2-Leg Tables

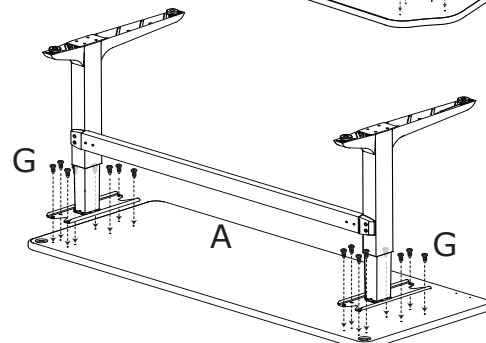

## 5 Adjust Workcenter Height

**For safety and ease of adjustment, set workcenter height while table is upside down.** Pull Ring Pins from each leg and raise or lower legs to desired height, then re-insert pins.

 Be sure to check legs for even adjustment before turning the workcenter back to its upright position.

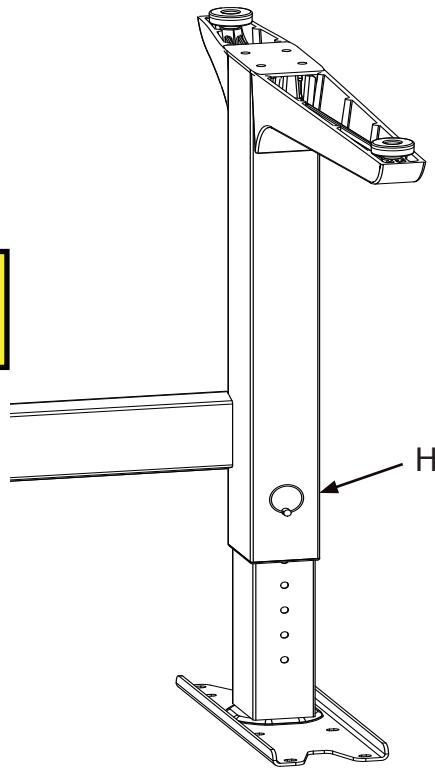

---

### Cleaning instructions

To clean the Sierra legs, simply use plain water and a soft cloth.

## Replacement Part Numbers

### Feet:

6400341-01: Sierra Foot, Short (5 $\frac{3}{8}$ " ), Sierra Silver  
6400341-02: Sierra Foot, Short (5 $\frac{3}{8}$ " ), Charcoal  
6400339-01: Sierra Foot, Medium (7 $\frac{7}{8}$ " ), Sierra Silver  
6400339-02: Sierra Foot, Medium (7 $\frac{7}{8}$ " ), Charcoal  
6400337-01: Sierra Foot, Long (14 $\frac{3}{4}$ " ), Sierra Silver  
6400337-02: Sierra Foot, Long (14 $\frac{3}{4}$ " ), Charcoal

### Legs:

6400413-01: Sierra End Leg - Sierra Silver  
6400413-02: Sierra End Leg - Charcoal  
6400414-01: Sierra Center Leg - Sierra Silver  
6400414-02: Sierra Center Leg - Charcoal  
Please call factory for assembled leg kits. (Leg assembly includes leg, bracket, feet and glides.)

### Crossbar Assemblies:

6000005-01-(YY)-2LEG: Sierra Silver Cross Bar Assembly for 2-leg workcenters  
6000005-02-(YY)-2LEG: Sierra Charcoal Cross Bar Assembly for 2-leg workcenters  
6000005-01-(YY)-3LEG: Sierra Silver Cross Bar Assembly for 3-leg workcenters  
6000005-02-(YY)-3LEG: Sierra Charcoal Cross Bar Assembly for 3-leg workcenters  
("YY" is the cross bar length in inches.)  
(All assemblies include mounting brackets and necessary screws.)

### Crossbar Components:

6400334-01: Bracket, X-bar Mount, Side, Sierra Silver  
6400334-02: Bracket, X-bar Mount, Side, Charcoal  
6400335-01: Bracket, X-bar Angled 90 Deg, Sierra Silver  
6400335-02: Bracket, X-bar Angled 90 Deg, Charcoal  
6400353-01: Bracket, X-bar Angled 120 Deg, Sierra Silver  
6400353-02: Bracket, X-bar Angled 120 Deg, Charcoal  
6000005-01-(YY): Sierra Silver Cross Bar ("YY" is length in inches) (*no mounting hardware included*)  
6000005-02-(YY): Sierra Charcoal Cross Bar ("YY" is length in inches) (*no mounting hardware included*)

### Top Brackets:

6400336: Bracket, Worksurface Mount  
6400348: Bracket, Corner, Worksurface Mount

### Miscellaneous Hardware:

3300353: Screw # $\frac{1}{4}$ -20 X  $\frac{5}{8}$  Buttonhead Allen Black  
3300252: AWC Leveling Glide 1- $\frac{3}{8}$  Hank Glide  
3300085: Screw #12 X  $\frac{3}{4}$ " Pan Phillips head Zinc Sheetmetal  
3300276: Ring Pin