

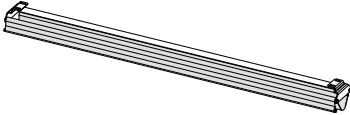





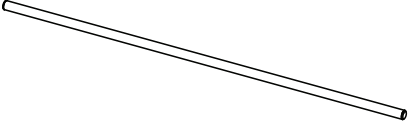

Sierra Modesty Screen Assembly Instructions

List of Parts, grouped by carton

<p>A Assembled Modesty Screen Qty: 1</p> 	<p>D Spacer Qty: 1</p>  <p>E Counterweight Tube Qty: 1</p>  <p>F #8 x 3/4" Phillips head Screws Qty: 4</p>  <p>G Push-in Fasteners Qty: 2</p> 
<p>B Crossbar Mount Left Flange Qty: 1</p>  <p>C Crossbar Mount Right Flange Qty: 1</p> 	

1

Verify that you have all the hardware and tools needed for the assembly

Check your cartons against the list on page 2 to verify that you have all the parts needed.

You will also need the following tools:

#2 tip Phillips screwdriver or drill bit
#3 tip Phillips screwdriver or drill bit

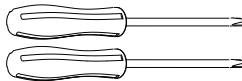

or

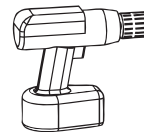



If you do not have a Workrite tabletop, you will also need a:

1/8" pilot drill bit



Important Note
 You will need someone to hold the screen in place for you until you have secured it to the workcenter.

Important Note
 You might need to reposition the control box if it is in the way of the Modesty Screen assembly! Do this before proceeding.

Important Note
 Raise Sierra workcenter to its highest position for ease of installation.

2 Get to know your Assembled Modesty Screen

The Assembled Modesty Screen (Part A) comprises the screen fabric, three tubes, and brackets for attaching the assembly to your workcenter.

The tube to which the fabric is attached will be referred to in this document as the Fixed Tube. It will be positioned on the side of the assembly closest to the user.

The tube over which the fabric hangs will be referred to in this document as the Free Tube. It will be positioned on the side of the assembly closest to the edge of the workcenter.

The small tube that is connected to the free end of the fabric that hangs down in front of the Cross Bar of the workcenter will be referred to in this document as the End Tube.

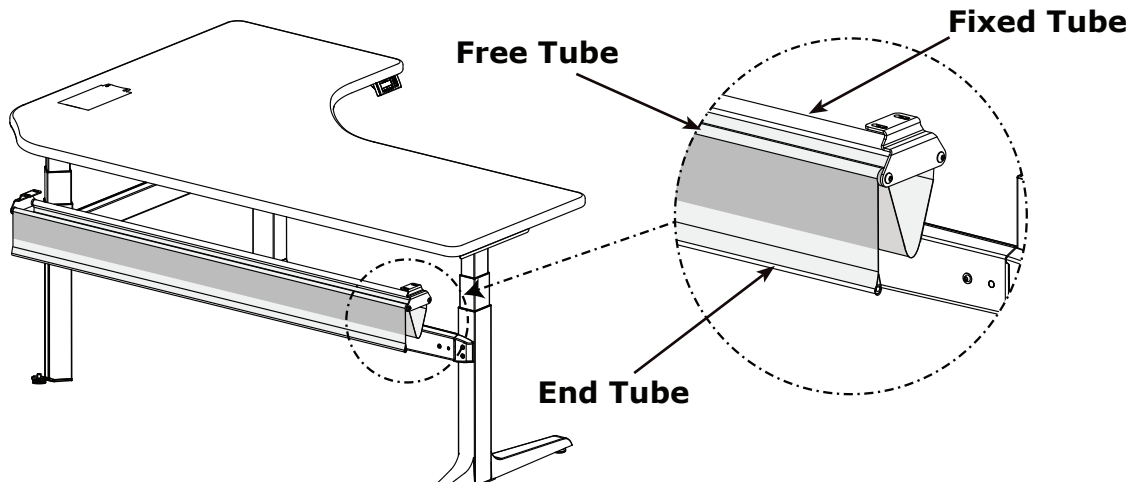

3 3-Leg Tables Only: Attach Center Leg Bracket

For 2-Leg table assembly, please proceed to Step 5.

- a** Unroll Modesty Screen, allowing it to fall straight down from Fixed Tube, behind crossbar.
- b** Remove near-inside screw of center leg bracket.
- c** Place forward hole of table bracket over screw hole, then loosely reattach screw through table bracket and leg bracket. Continue to Step 3c on following page.

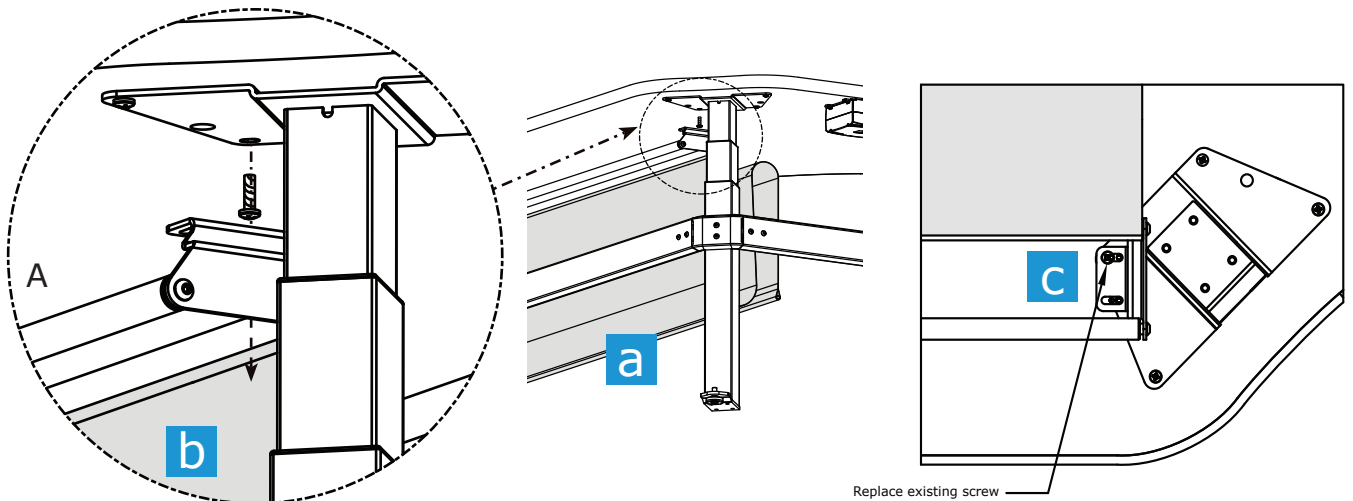

3 3-Leg Tables Only: Attach Center Leg Bracket, continued

- c** Position back of table bracket so that second hole aligns with extra hole in center leg bracket.*
- d** Drill pilot hole, then loosely attach second screw.

 *** Note: If your center leg bracket does not have an extra hole, please call Customer Service.**

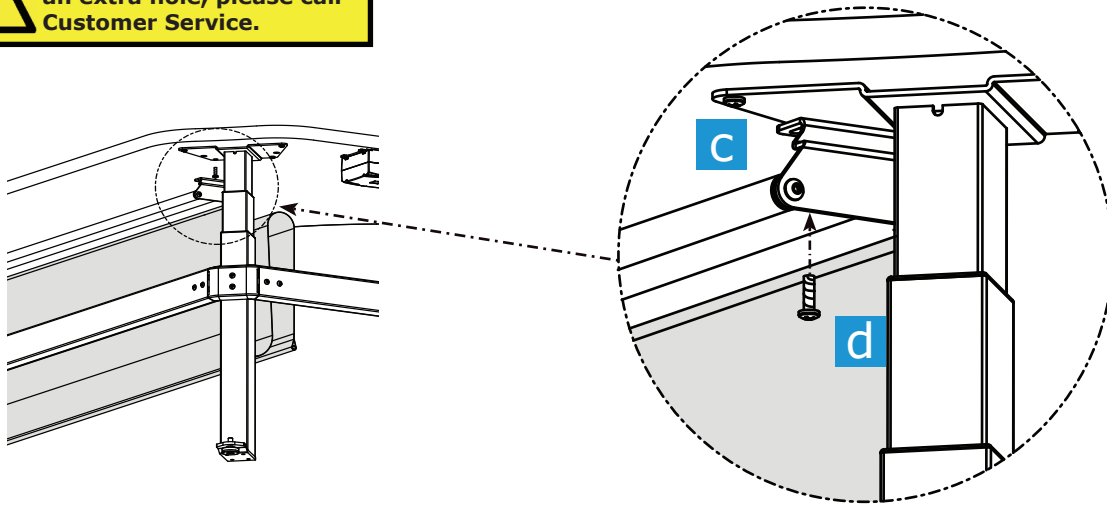

4 3-Leg Tables Only, continued: Attach Outer Leg Bracket

- a** Place Spacer between bracket and workcenter top. Position long end of Spacer flush against leg bracket, with short end $3\frac{5}{8}$ " from the outside rear edge of the leg bracket. Drill pilot holes in top.
- b** Align holes in bracket with holes in Spacer, and attach bracket to workcenter top through Spacer with 2 screws.
- c** Tighten screws on center leg bracket.
- d** Skip to Step 6.

 **It is easiest to attach bracket if Modesty Screen is allowed to fall straight down from Fixed Tube, behind cross bar.**

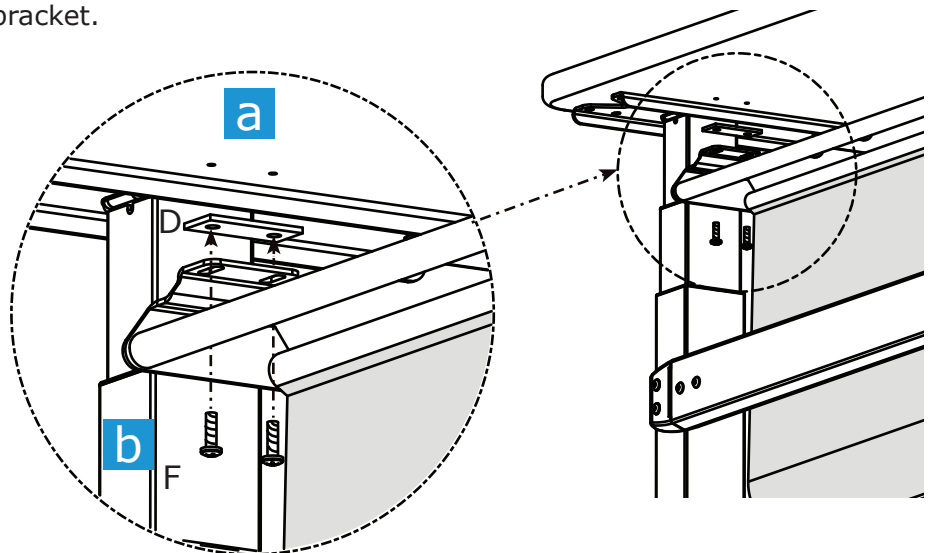
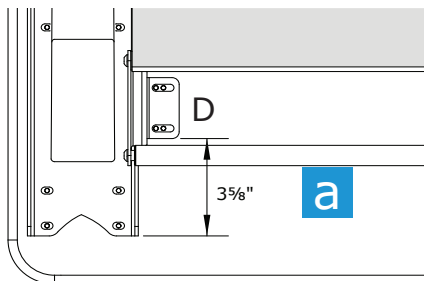

5 2-Leg Workcenters Only: Attach Leg Brackets

For 3-Leg workcenters, please proceed to Step 6.

- a** Position Modesty Screen so that the outside edge of the top bracket is $3\frac{5}{8}$ " from the outside rear edge of the leg bracket, and the entire assembly is parallel to the outside edge of the workcenter. Drill pilot holes.
- b** Loosely attach bracket to one side of workcenter top with 2 screws.
- c** Attach bracket to other side of workcenter with remaining 2 screws.
- d** Tighten all screws.

! When placing Modesty Screen for attachment to workcenter, the Fixed Tube should be closest to the inside of the table. The Free Tube should be closest to the outside edge of the workcenter.

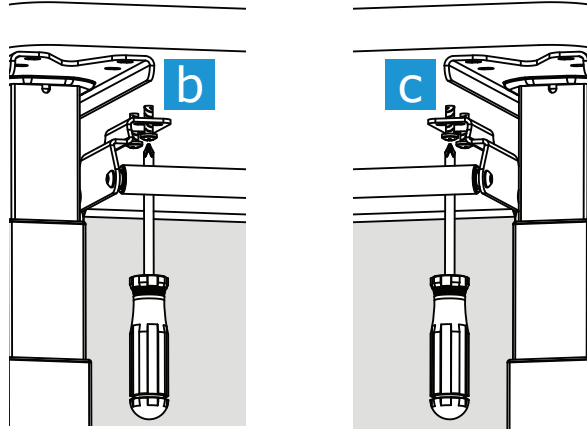
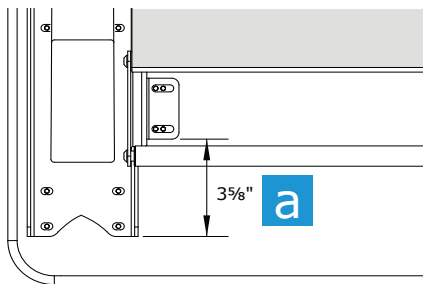

6 All workcenters: Attach Crossbar Mounts to Crossbar

- a** **For 2-leg workcenters and outside leg of 3-leg workcenters:** Remove outer crossbar screw, closest to leg.

For center leg of 3-leg workcenters:
Remove inner crossbar screw, farthest from leg.

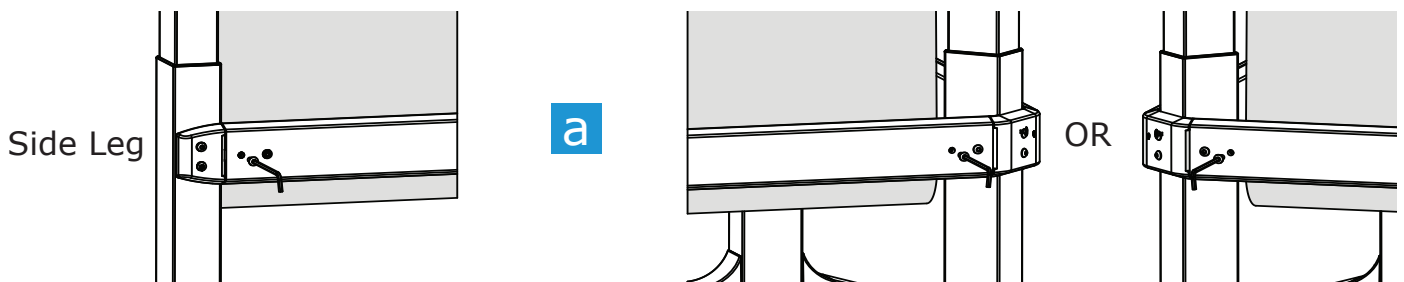

- b** Attach Crossbar Mounts to crossbar, reattach screws.

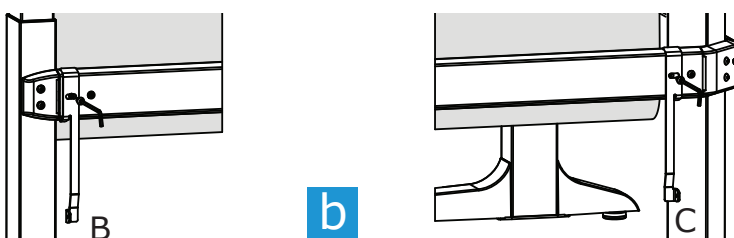

7 Position End Tube

- a Feed fabric up and over Free Tube, aligning End Tube with holes in Crossbar Mounts.
- b Insert Push-in Rivet Fasteners in each side of End Tube through Crossbar Mounts.

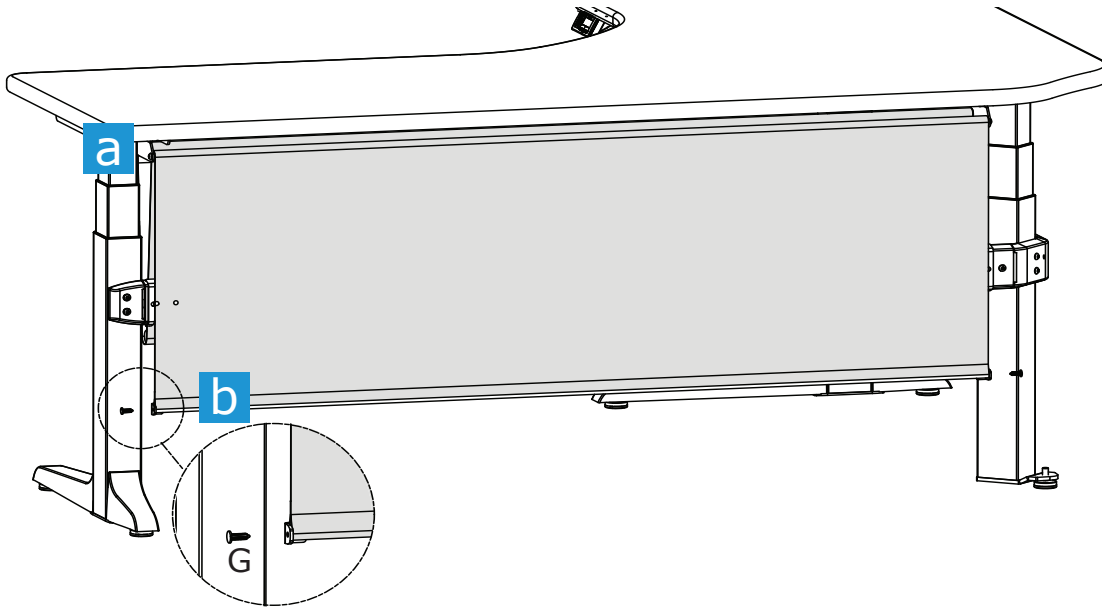

8 Attach Counterweight Tube

Attach Counterweight Tube by sliding it into place on the desk side of the crossbar, in the "V" made by the hanging fabric.

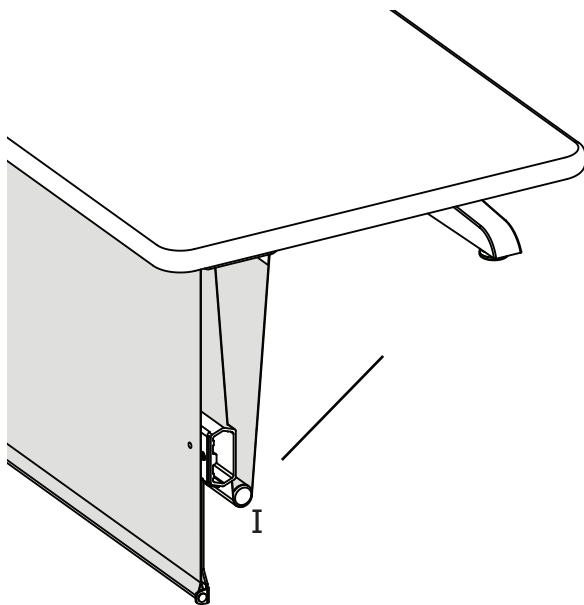

9 Test Modesty Screen

- a** Raise your Sierra Workcenter to your standing position, checking to be sure the Modesty Screen extends properly to its fullest length.
- b** Lower your Sierra Workcenter to your seated position, checking to be sure the Modesty Screen retracts correctly and does not buckle or catch on anything.

Congratulations! Your Modesty Screen installation is complete.

