

Installation Instructions

# Workrite Poise™

**Workrite**  
ergonomics®

# **Workrite Poise™**

---

## *FLAT SCREEN MONITOR ARM*

### **Contents**

Important Safety Instructions .....	2
Components and Fasteners .....	3
PA1000 Assembly Instructions.....	4
LCD Monitor Attachment.....	5
Cable Management .....	6
Arm Adjustment .....	7
Desk Base Template.....	8

### **Important Safety Instructions**

Read and understand all these safety instructions before using the product.





Do not mount the Desk Base of the Arm on an unstable surface or any surface that could not mount the Desk Base firmly.





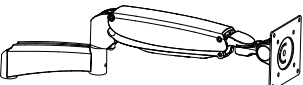



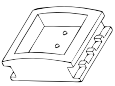

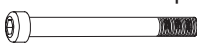

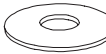

For safety reasons, the internal gas-strut of the LCD Arm product was pre-adjusted in the factory to the lowest force to prevent the Arm body from being recoiled during installation.

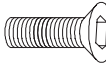
During installation, beware of the recoil of the Arm body when attaching or detaching the LCD monitor to the Arm. To prevent damage or injury when changing the LCD monitor, always readjust the gas-strut to the lowest force level to control the recoil of the Arm body when the LCD monitor is detached.

Do not attempt to disassemble, service or modify the product by yourself.

Use only a slightly damp cloth to clean the Arm surface. Never apply flammable solvents like alcohol, benzene, thinner, etc. to the product.

Components	
<b>A</b> Desk Base with Clamp	x1
	
<b>B</b> Arm Assembly	x1
	
<b>C</b> Plastic Cap	x1
	
<b>D</b> Base Cushion	x1
	
<b>E</b> U Bracket	x1
	
<b>F</b> Holding Tab	x8
	

Fasteners	
<b>a</b> Plastic Spacer	x1
	
<b>b</b> Round Head Cap Screw	x1
	
<b>c</b> Washer	x2
	
<b>d</b> Disc Spring Washer	x 1
	
<b>e</b> M5 Hex Wrench	x1
	
<b>f</b> M8 Thread Rod	x1
	
<b>g</b> Wing Nut	x1
	
<b>h</b> M4 Hex Wrench	x1
	
<b>i</b> M8 Flat Head Cap Screw	x2
	
<b>j</b> Round Head Cap Screw	x2
	
<b>k</b> M4 6mm Screw	x4
	
<b>l</b> M4 10mm Screw	x4
	
<b>m</b> Cable Clip	x1
	
<b>n</b> M5 10mm Set Screw	x1
	
<b>o</b> M3 6mm Screw	x2
	
<b>p</b> M2.5 Hex Wrench	x1
	

# PA1000 Assembly Instructions

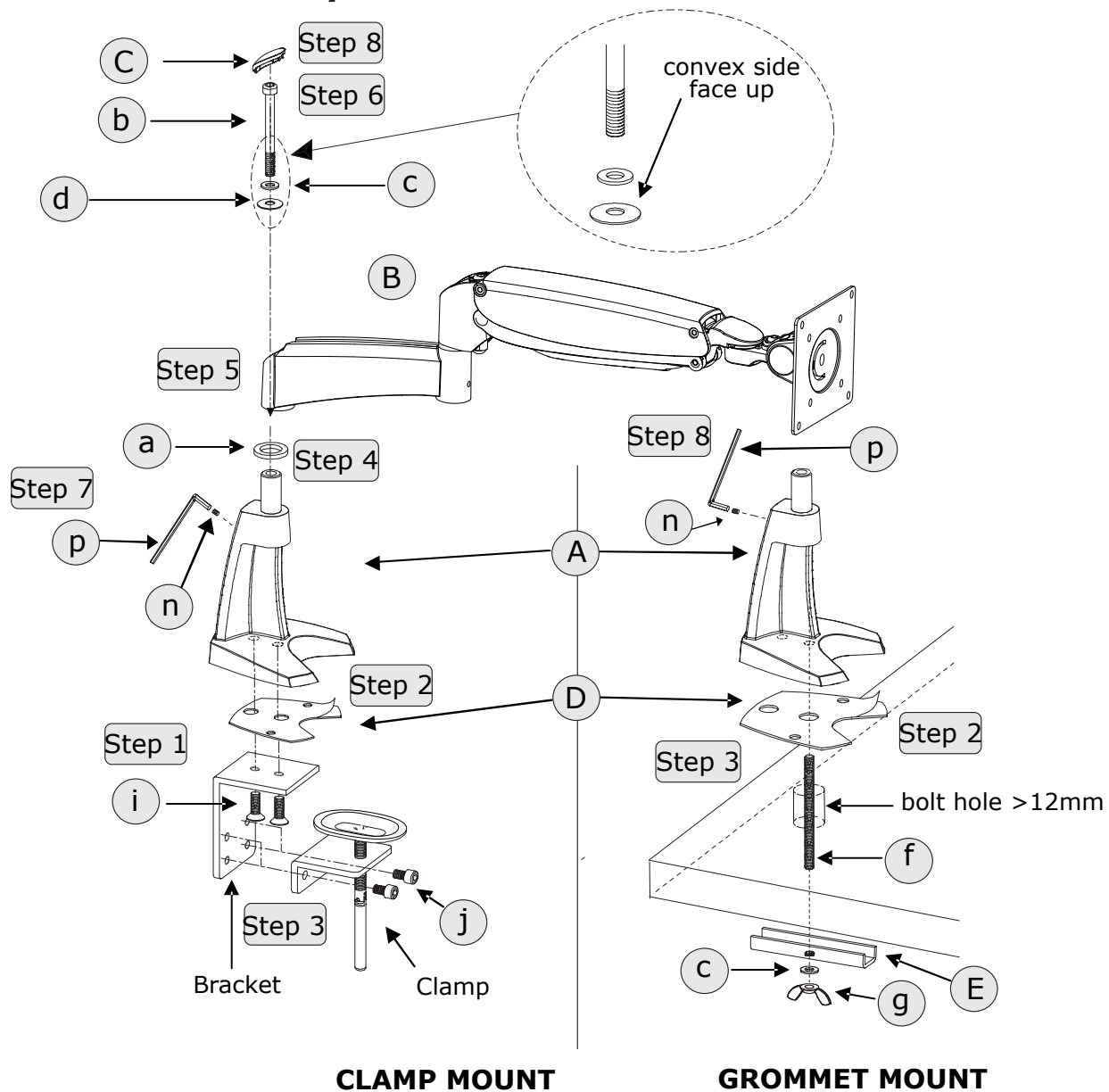

## Steps:

### Clamp Mount:

- 1 Mount Bracket to Desk Base then tighten (i) Flat Head Cap Screws with (e) M5 Hex Wrench.
- 2 Attach (D) Base Cushion to (A) Desk Base.
- 3 Put Desk Base onto work surface then mount Clamp to the Bracket then tighten (j) Round Head Cap Screw with (e) M5 Hex Wrench.
- 4 Put (a) Plastic Spacer over (A) main shaft of Desk Base.
- 5 Put (B) Arm Assembly onto the main shaft.
- 6 Insert (b), (c) and (d) into Arm Assembly and tighten with (e) M5 Hex Wrench. Be sure arm rotates freely.
- 7 Insert (n) Set Screw in back of Desk Base and tighten with (p) M2.5 Hex Wrench.
- 8 Snap (C) Plastic Cap into the top of Arm Assembly.

### Grommet Mount:

- 1 Remove the Bracket from (A) Desk Base with (e) M5 Hex Wrench (not illustrated).
- 2 Attach (D) Base Cushion to (A) Desk Base.
- 3 Use template on page 8 to drill bolting hole in work surface if needed. Put Desk Base directly on the bolting hole of work surface and tighten (f) M8 Thread Rod with (h) M4 Hex Wrench. Insert (E) U Bracket & (c) Washer through (f) M8 Thread Rod and tighten them with (g) Wing Nut.
- 4 Follow Desk Mount Steps 4 to 8.

## LCD Monitor Attachment

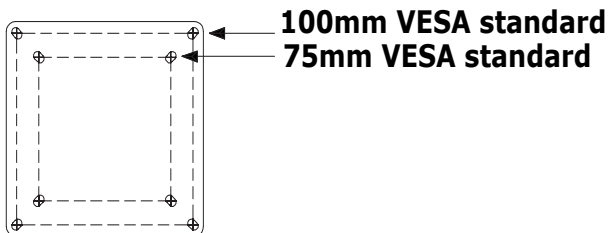
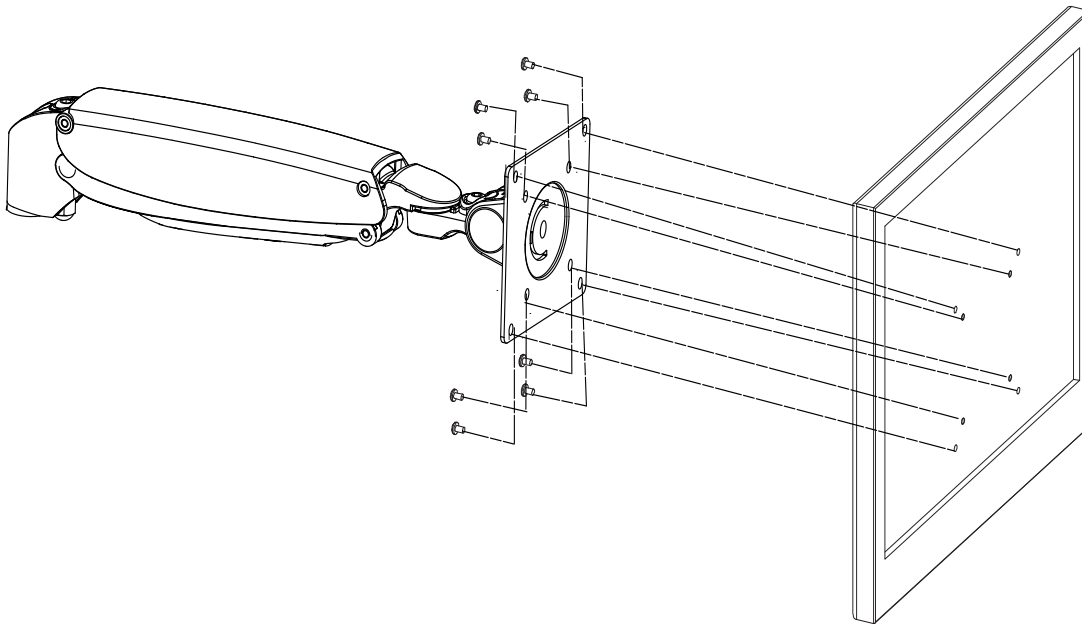

The combination 75/100mm VESA plate is pre-mounted to the Workrite Poise.

Mount the LCD monitor directly to the front plate of the Tilt Adjustment Pivot with the supplied M4 x 6mm (or M4 x 10mm) screws or screws provided by the manufacturer.

For 100mm x 100mm or 75mm x 75mm standard, use the 4 outer corner holes or 4 inner corner holes on the front plate respectively.

### **IMPORTANT**

**It is strongly recommended to use the mounting screws provided by the LCD monitor manufacturer. Due to the varieties of monitor mounting design, the mounting holes at the back of the LCD monitor might not be suitable for the M4 screws provided by our Product. Using unsuitable mounting screws might cause damage to the LCD monitor. Please consult your LCD monitor manufacturer if you have enquires.**

## Cable Management

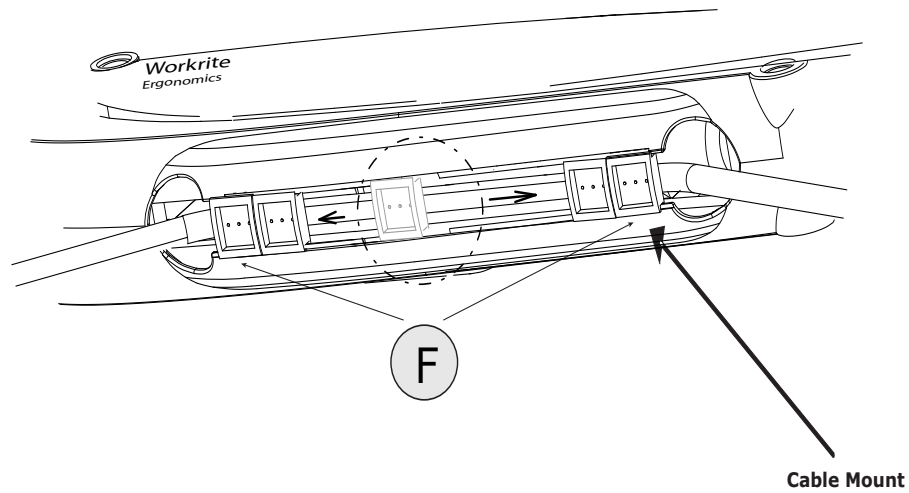

### **FOREARM**

- 1 Thread monitor cables through Cable Mount located on underside of Forearm.
- 2 Place Holding Tabs (F) in center slot as shown and slide into place along Mount track. Use four tabs on each side.

### **EXTENSION**

Secure Velcro® strips under side of Extension around monitor cables, leaving slack for monitor cables to move freely.

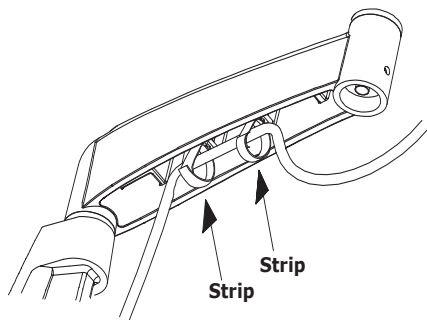

### **DESK BASE**

Attach the Cable Clip to the back of the Desk Base with the supplied M3 Screws (o) and put cables into the Cable Clip.

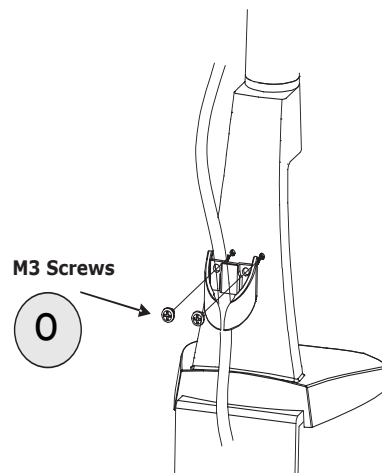

Note:  
To allow free movement of monitor and Arm/Extension, please leave sufficient slack in the cables.

## Arm Adjustment

### Adjust the Monitor Tilt Action

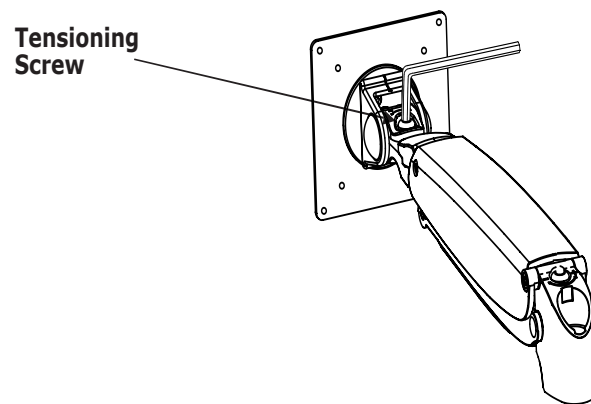

Depending on the size of your LCD monitor, it may be required to adjust the Tilt Adjustment screw. If the monitor doesn't hold its tilt position or is too hard to tilt, adjust the screw directly behind the LCD screen with the M5 Allen wrench provided (clockwise to tighten, counter-clockwise to loosen as shown on the graphic near the adjustment screw). Check the monitor, and adjust again as necessary.

### Vertical Movement

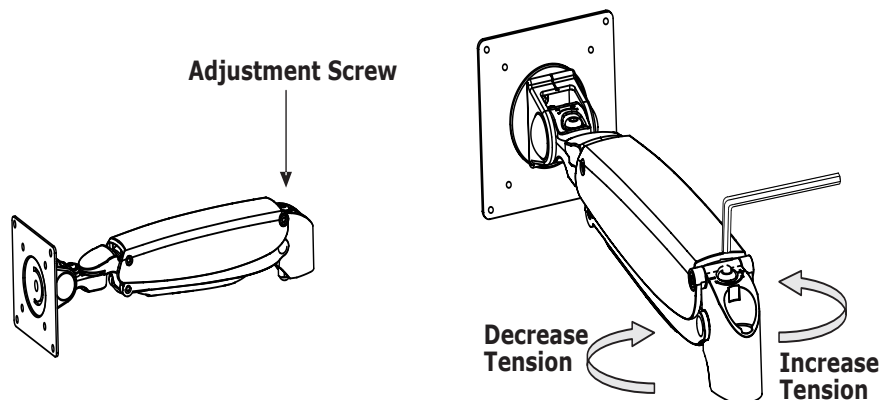

Depending on the weight of the monitor, adjustments may be required to the Arm. This can be done by using the M5 Hex wrench provided.

### **IMPORTANT**

**When performing this adjustment, the Arm must be in a HORIZONTAL position as shown above. To prevent damage to the aluminium Arm body, remove the M5 Hex Wrench before releasing the Arm from the horizontal adjustment position.**

If the Arm tends to drift down or rise up when positioned, it will be necessary to make small adjustments at the Adjustment Screw. The above shows the adjusting method. The M5 Hex wrench provided should be used to make this adjustment.

If the Arm tends to rise, the M5 Hex Wrench should be turned clockwise to decrease the tension until the Arm reaches a stable position.

If the Arm tends to fall, the M5 Hex Wrench should be turned counter-clockwise to increase the tension until the Arm reaches a stable position.

## Desk Base Template for Grommet Mount

Drill hole at least ½" in diameter

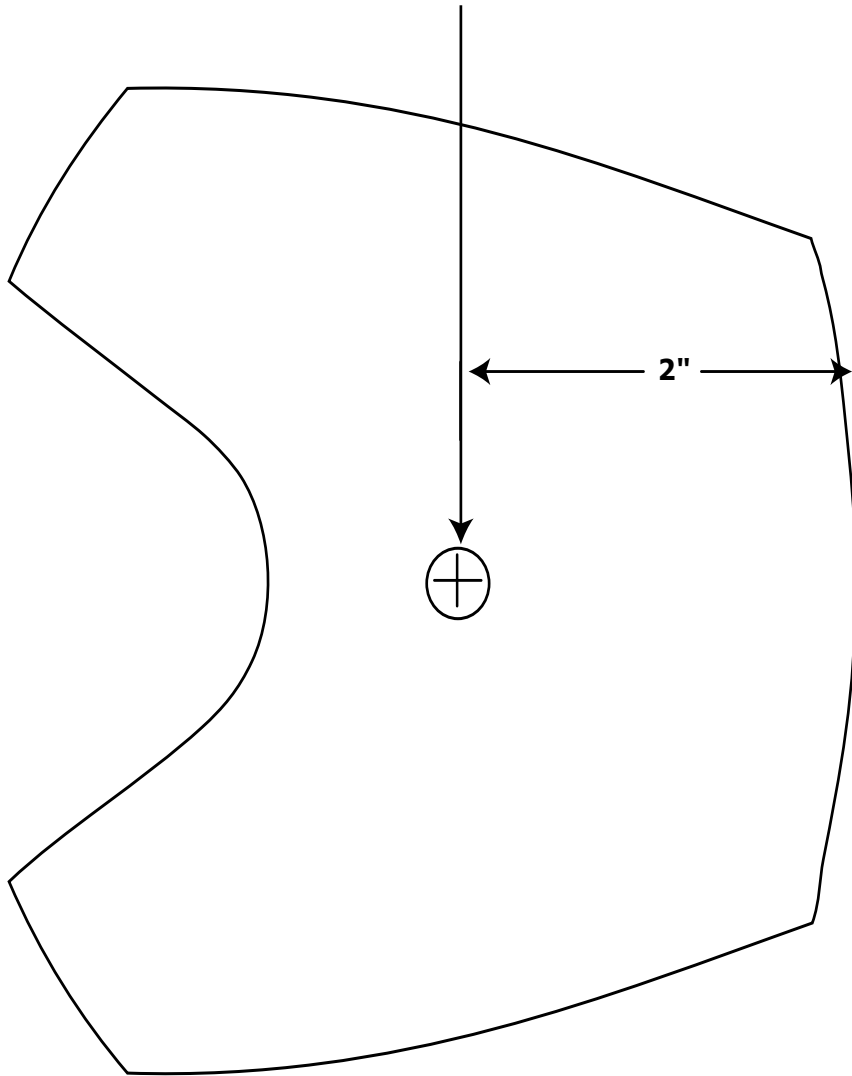

Workrite reserves the right to make changes to its products without notice. No liability is assumed for any misprinting or error in this publication. Copyright 2009. All rights reserved.