

Verano Installation Instructions — *single unit, or parent unit of daisy chain*
(see reverse for child unit installation)

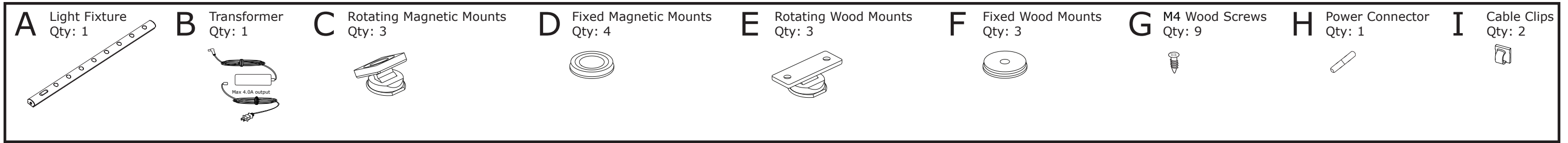

1 Determine if light will be affixed to a metal or wood cabinet and follow the appropriate step below.
If installing parent unit of daisy chain, be sure to position parent unit so that it can be connected to the additional unit with its supplied jumper cable.

2 Metal cabinet mounting:

- a** Snap Magnetic Mounts (C or D) onto back rail. For Rotating Mounts, orient flat sides of Magnetic Mounts with the length of the Verano.
- b** Attach Light Fixture (A) to metal under-cabinet. Magnets will hold Verano in place.

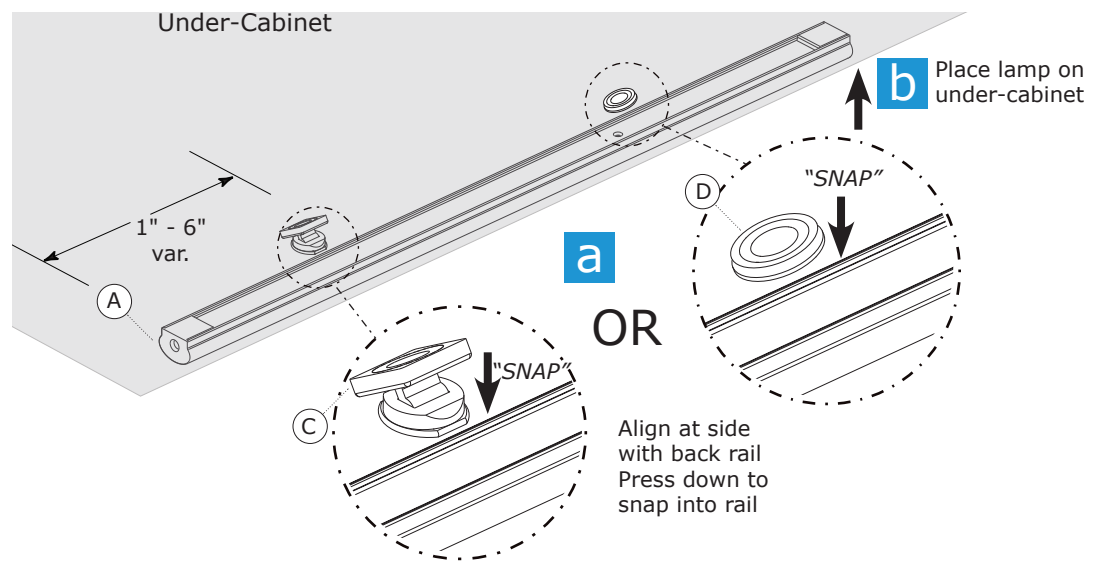

! Note: All mount options allow fixture to slide from side to side - mounts can be positioned up to 6" from edge of fixture.

Wood cabinet mounting:
Note: You will need a Phillips-head screwdriver to complete this step.

- a** Attach Wood Mounts (E or F) to underside of cabinet with Wood Screws. (G). If using 3 mounts, be sure they are positioned in a straight line.
- b** Snap Light Fixture (A) onto mounts to hold in place.

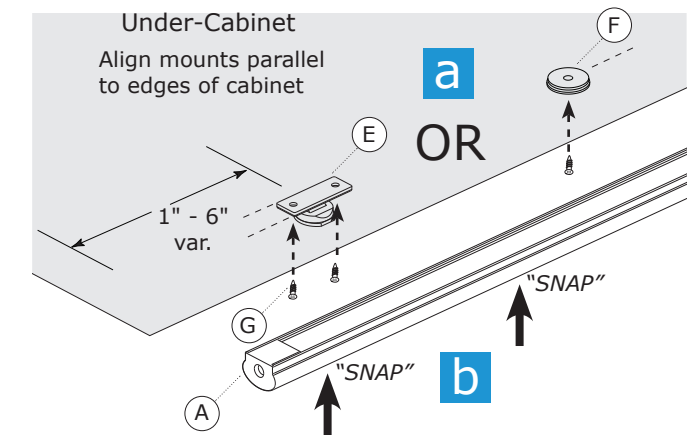

- 3**
- a** Plug transformer (B) into wall
 - b** Plug power cord into Verano unit end
 - c** Press power button on Verano to turn on/off.
 - d** Use Cable Clips (I) as needed to secure cord.

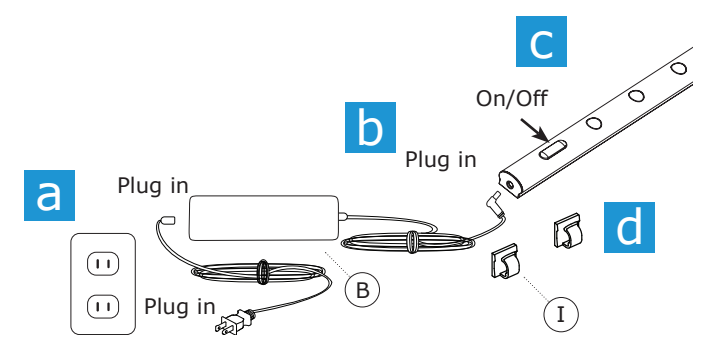

! **CAUTION** – To reduce the risk of fire, electric shock or injury to persons refer to the chart at right for maximum daisy-chained units:

Maximum Daisy-chained units: Number of fixtures within same chain with 4.0A 12V transformer

VER-24	1	1	2		1	1	2	2	3		4
VER-36	1		1	2	1	2	1			3	
VER-48		1	1		2	1			1		
Total/Chain	2	2	2	2	2	2	3	3	3	3	4

Replacement parts

- Daisy Chain Jumper Cords, 24" VER-DC24
- Daisy Chain Jumper Cords, 48" VER-DC48
- Max 4.0A (12 volt) transformer VER-T45
- Verano hardware pack (contains qty 3 each of parts C, E and F, 4 of D, and qty 9 of G) VER-HDWR

Verano Installation Instructions — *child* daisy chain units
(see reverse for single or parent unit installation)

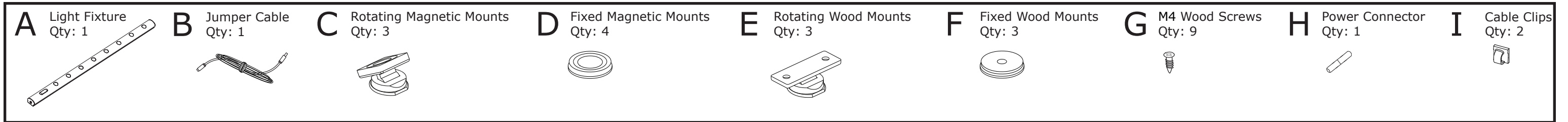

1 Determine if light will be affixed to a metal or wood cabinet and follow the appropriate step below.

Be sure to position daisy-chained unit so that it can be connected to the previous unit with its supplied jumper cable.

2 Metal cabinet mounting:

- a** Snap Magnetic Mounts (C or D) onto back rail. For Rotating Mounts, orient flat sides of Magnetic Mounts with the length of the Verano.
- b** Attach Light Fixture (A) to metal under-cabinet. Magnets will hold Verano in place.

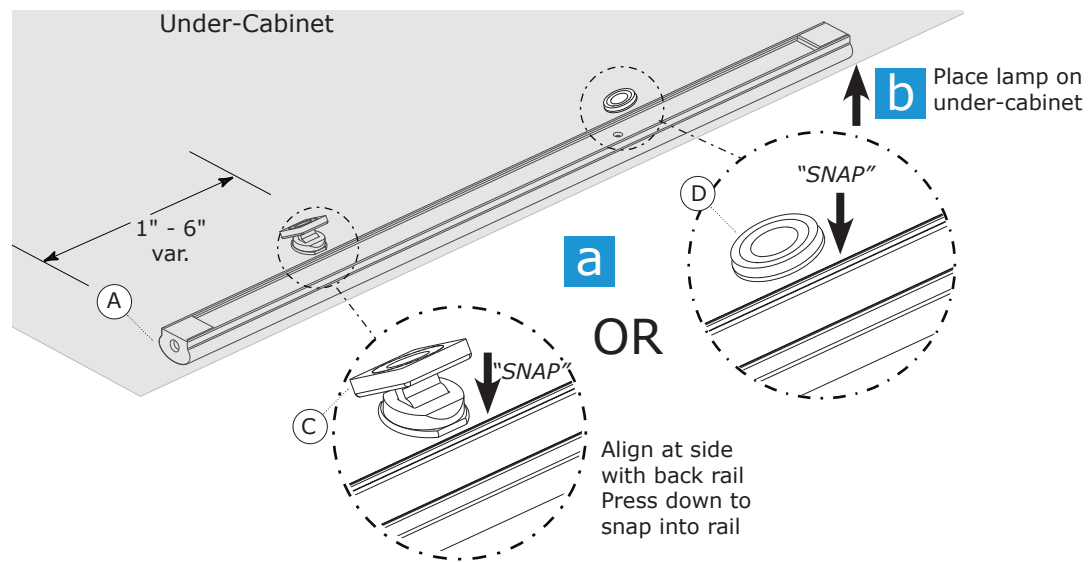

! Note: All mount options allow fixture to slide from side to side - mounts can be positioned up to 6" from edge of fixture.

Wood cabinet mounting:

Note: You will need a Phillips-head screwdriver to complete this step.

- a** Attach Wood Mounts (E or F) to underside of cabinet with Wood Screws (G). If using 3 mounts, be sure they are positioned in a straight line.
- b** Snap Light Fixture (A) onto mounts to hold in place.

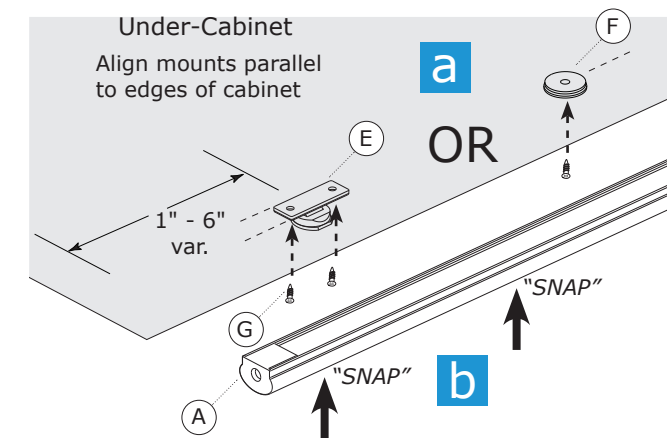

3 a Connect daisy-chained Verano unit to previous unit with the supplied Jumper Cable (B), or use Power Connector (H) to join two fixtures together. Plug power cord into Verano unit end.

- b** Press power button on Verano to turn on/off.
- c** Use Cable Clips (I) as needed to secure cord.

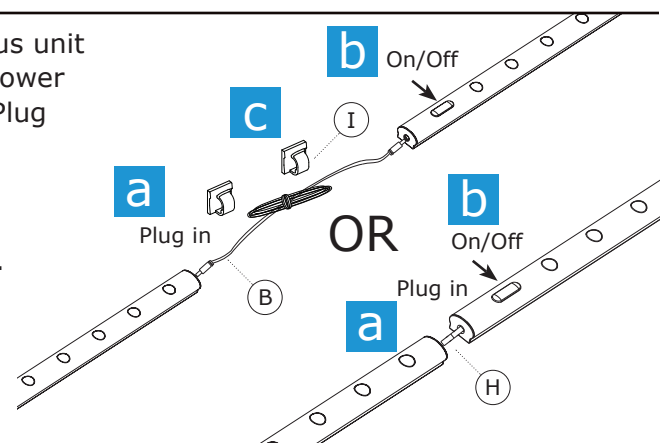

! **CAUTION** – To reduce the risk of fire, electric shock or injury to persons refer to the chart at right for maximum daisy-chained units:

Maximum Daisy-chained units: Number of fixtures within same chain with 4.0A 12V transformer

VER-24	1	1	2	2	1	1	2	2	3	4
VER-36	1	1	2	2	1	2	1	3	3	
VER-48	1	1	2	2	1	1	1	3	3	3
Total/Chain	2	2	2	2	2	2	3	3	3	4

Replacement parts

Daisy Chain Jumper Cords, 24"	VER-DC24
Daisy Chain Jumper Cords, 48"	VER-DC48
Max 4.0A (48 watt) transformer	VER-T45
Verano hardware pack (contains qty 3 each of parts C, E and F, 4 of D, and qty 9 of G)	VER-HDWR