

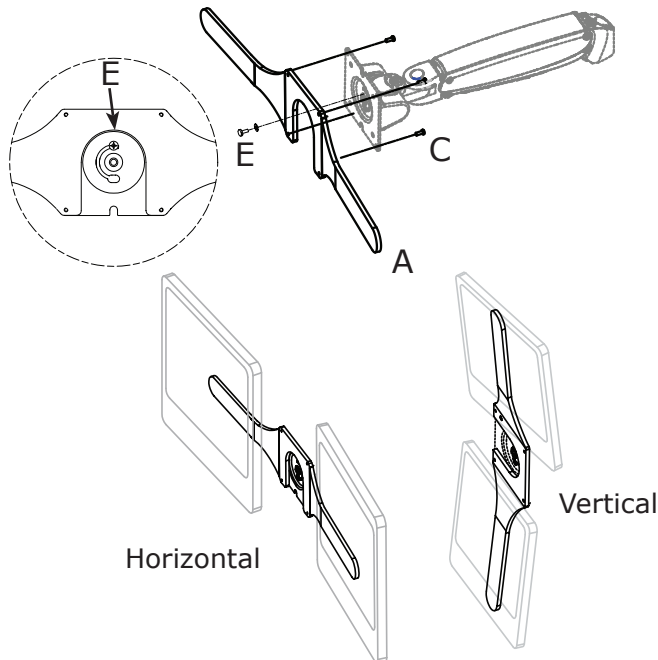

1 Attach the Wing Bracket (A) to the Poise HD forearm VESA 100 Mount using the four M4x10mm screws (C) (horizontal orientation shown) . Be sure to tighten securely. Attach M4x8mm screw and washer (E) to lock pivot.

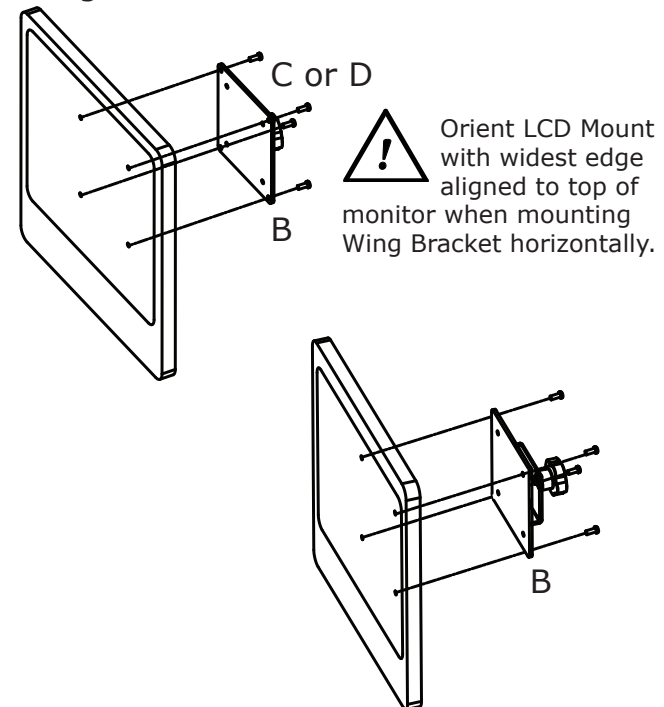

2 Attach each LCD Mount to the monitors with four M4 screws (C or D). Be sure both LCD Mounts are aligned in the same direction for the selected Wing Bracket orientation.



 Note: It is strongly recommended to use the mounting screws provided by the LCD monitor manufacturer. Due to the variety of monitor mounting designs, the mounting holes at the back of the LCD monitor might not be suitable for the M4 screws we have provided and could cause damage to the LCD monitor.

- 3** Slide the LCD Mounts on to the Wing Bracket (A) and tighten the clamp knob. Adjust as needed to center the LCD screens.

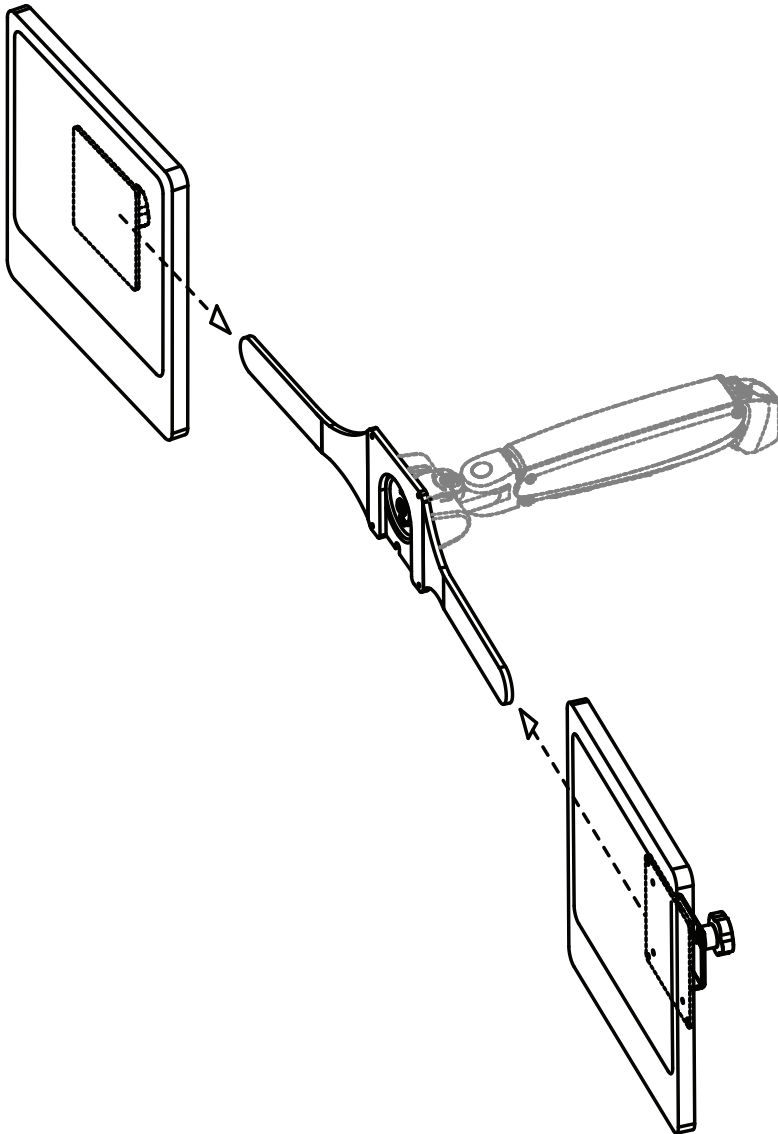

- 4** Install two M4x6mm screws (D) into the ends of the Wing Bracket (A) to prevent the LCD monitors from sliding off the Wing Bracket during use.

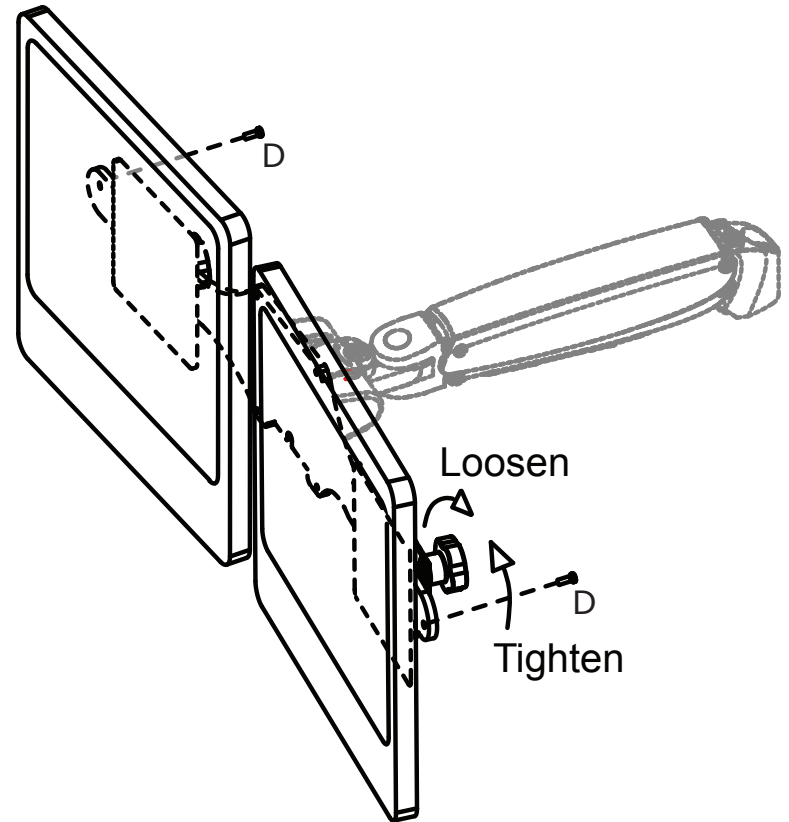

To adjust your monitor arm, see the section titled Arm Adjustments in your Poise HD Assembly Instructions.