

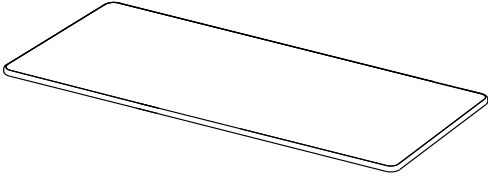

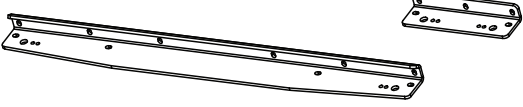

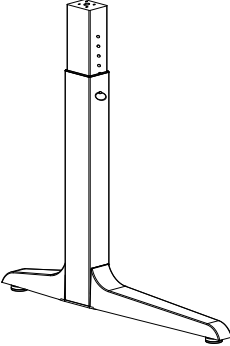

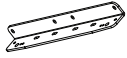
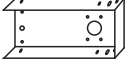

Workrite Sierra HX™ Pin
Assembly Instructions
for 2-Leg Pin models

Parts grouped by carton

<p>A Tabletop (size and shape differ for each model) Qty: 1</p> 	<p>B Long Brace Qty: 1</p> <p>C Short Brace Qty: 2</p> 	
<p>D Leg Qty: 1</p>  <p>E Medium Brace Qty: 1</p> 	<p>F Leg Cap Qty: 1</p>  <p>G 1/4-20 x 5/8" Button Head Machine Screws Qty: 8</p>  <p>H #12 x 3/4" Pan Head Sheetmetal Screw Qty: 32</p> 	<p>I 5/32" Allen Wrench Qty: 1</p>  <p>J #12 x 1/2" Button Head Machine Screws Qty: 12</p>  <p>K #10 x 3/8" Pan Head Type 23 Screw Qty: 36</p> 
<p>D Leg Qty: 1</p>  <p>E Medium Brace Qty: 1</p>  <p>F Leg Cap Qty: 1</p> 		

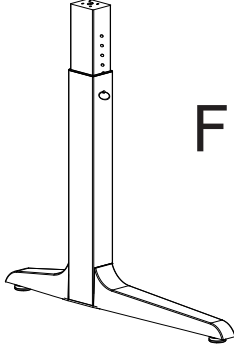
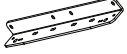
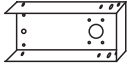
1 Verify that you have all the hardware and tools needed for the assembly

a Check your cartons against the list above to verify that you have all the parts needed.

You will also need the following tools:

#2 tip Phillips screwdriver or drill bit
#3 tip Phillips screwdriver or drill bit

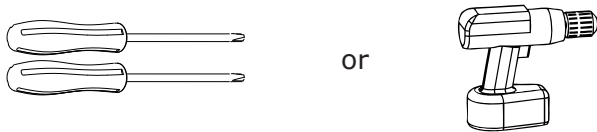

If you do not have a Workrite tabletop, you will also need:

1/8" pilot drill bit 

b Lay out the Legs (E), Leg Braces (B, C, and E), and Leg Caps (F) on the floor in the proper location.

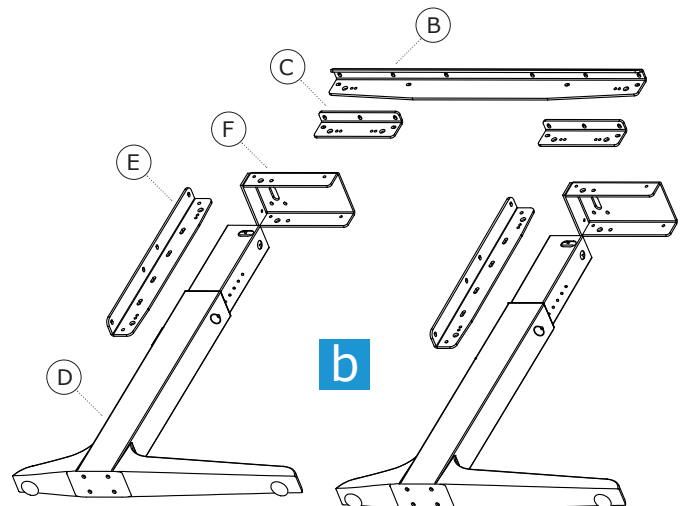

2 Assemble Legs

a Attach one Leg Cap (F) to the top of each Leg (D) using Button Head Screws (G). **Do not tighten screws completely.**

b With legs on their sides, attach Long Brace (B) to top of both Legs using Button Head Screws (J). The Brace should have the lip on top, facing away from the leg. **Do not tighten screws completely.**

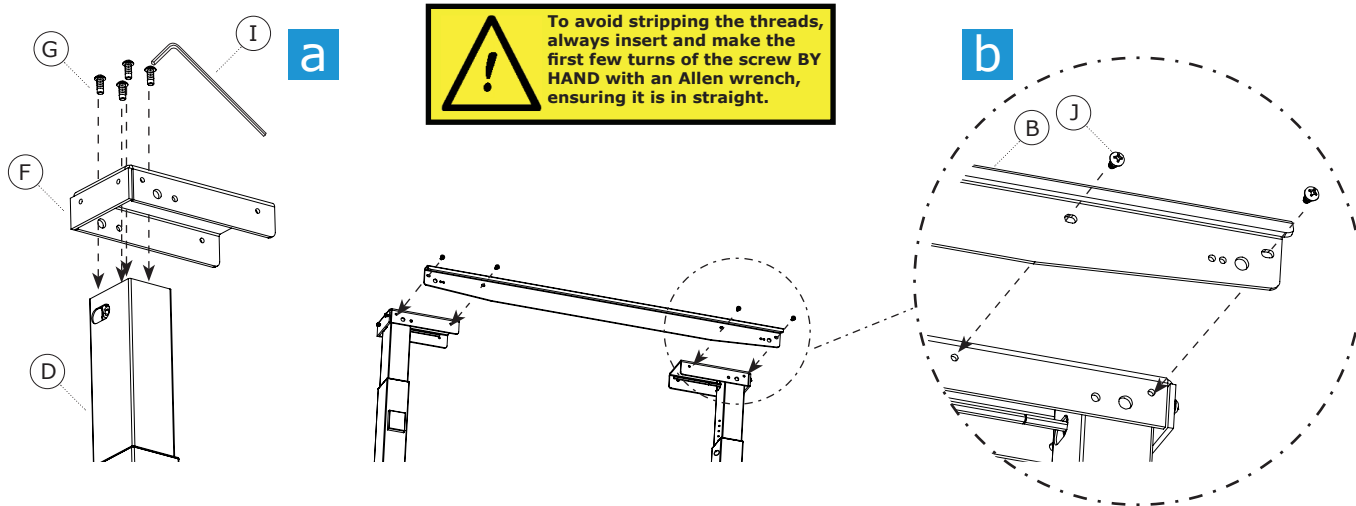

c Turn Leg Assembly upside down and attach both Short Braces (C) using Button Head Screws (J). **Do not tighten screws completely.**

d Attach Medium Braces (E) to sides of Legs using Button Head Screws (J). If you have a 24" deep or less worksurface, use the holes towards the back of the brace so that the brace extends out above the long part of the foot. For deeper worksurfaces, use the center holes of the brace so that it is centered on the leg. **Do not tighten screws completely.**

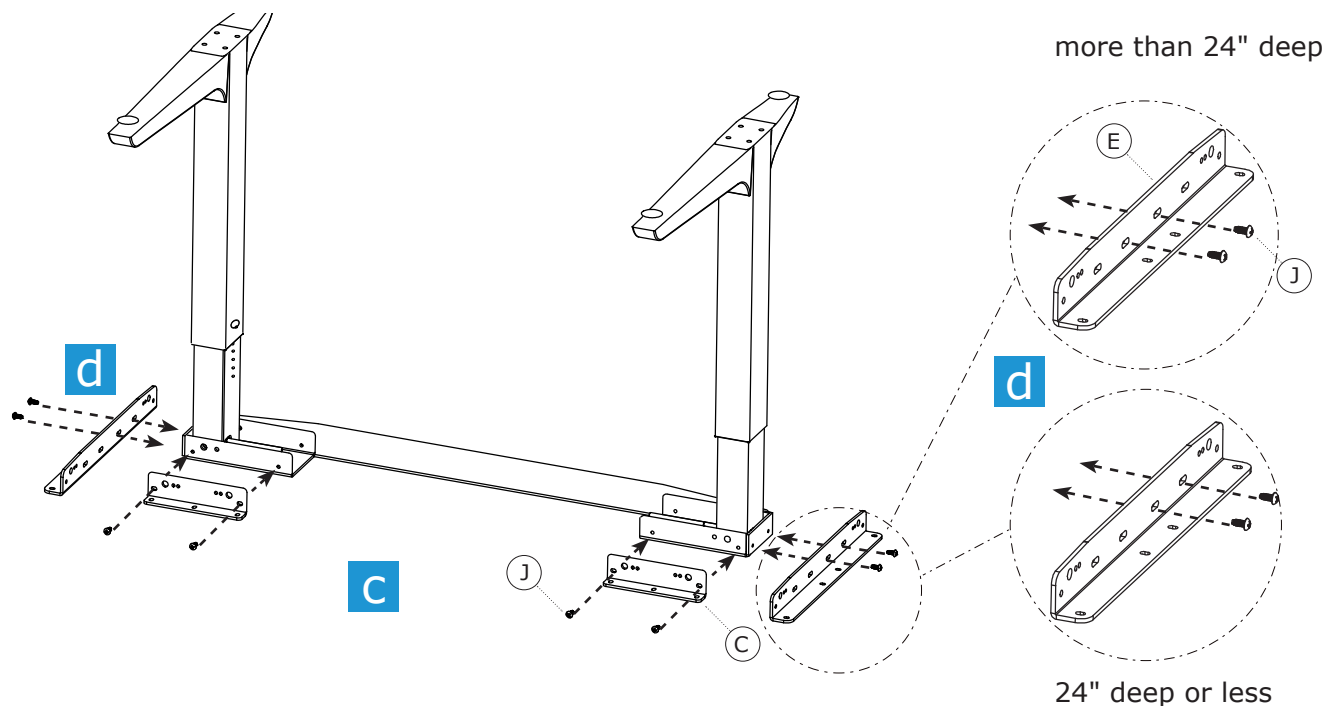

3 Attach the leg assembly to the worksurface

- a Lay out the leg assembly in the proper location. Adjust the leg assembly to make it line up with the locating holes. Attach assembly to Top (A) using 20 Pan Head Screws (H).
- b Tighten all screws completely.

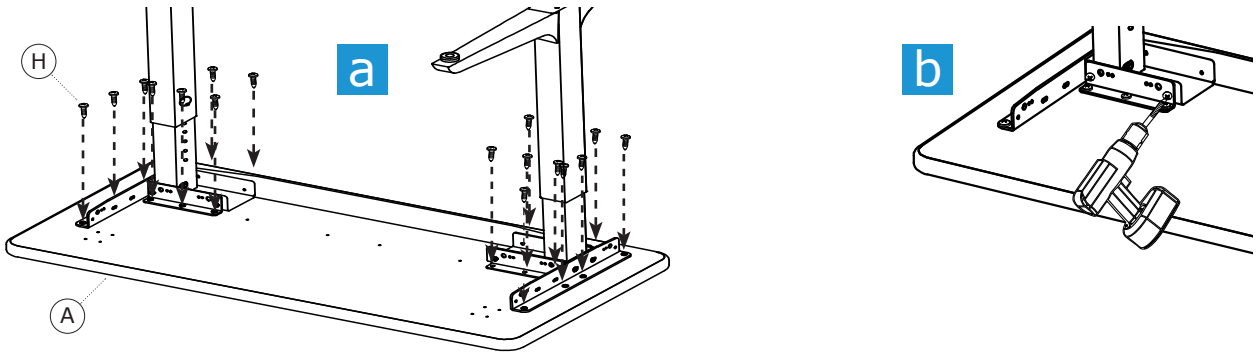

4 Adjust Workcenter Height

- a **For safety and ease of adjustment, set workcenter height while table is upside down.** Pull Ring Pins from each leg and raise or lower legs to desired height, then re-insert pins.

 Be sure to check legs for even adjustment before turning the workcenter back to its upright position.

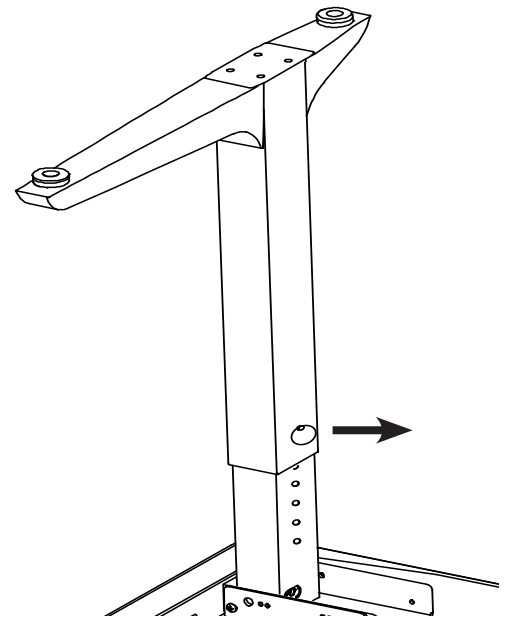

5 Flip Table Over

- a Flip table over and adjust Leveling Glides if required so that table is steady and does not rock.

