

# ***EconoLift™ Companion Table***

## ***Assembly Instructions***



**WORKRITE®**  
ERGONOMICS

1450 Technology Lane, Petaluma, CA. 94954

(800) 959-9675 Fax (800) 930-8989

1500053

# EconoLift™ Companion Table

## List of Materials

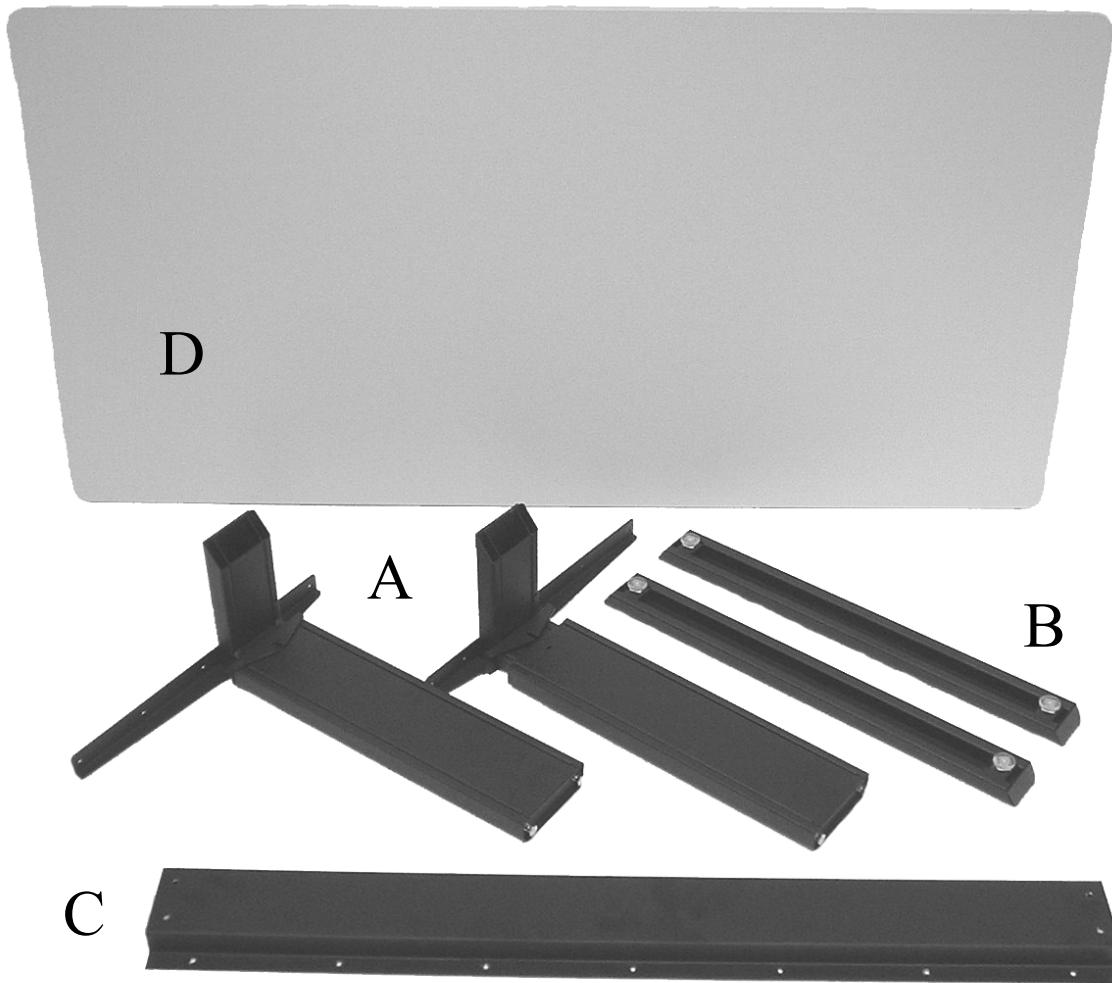

- A.) Legs (one left, one right)
- B.) Feet
- C.) Cross Bar (for 48" and longer units)
- D.) Top (if ordered with top)

### Required Tools List

- #3 tip Phillips screw driver
- 1/2" Socket Wrench

## Top Mounting Hardware List

- Qty 14. #12 x 3/4" wood screws. 24 screws if Cross Bar is included.
- Qty 2. #10 x 1" screws. 6 screws if Cross Bar is included.

## Step 1.

Remove the two (2) Hex Head Bolts from the end of the Leg. Line up the two holes in the Foot with the holes in the end of the Leg. Replace the Hex Head Bolts and tighten. Be sure to have the long end of the Foot directly over the long end of the bracket as shown. Repeat for other leg.

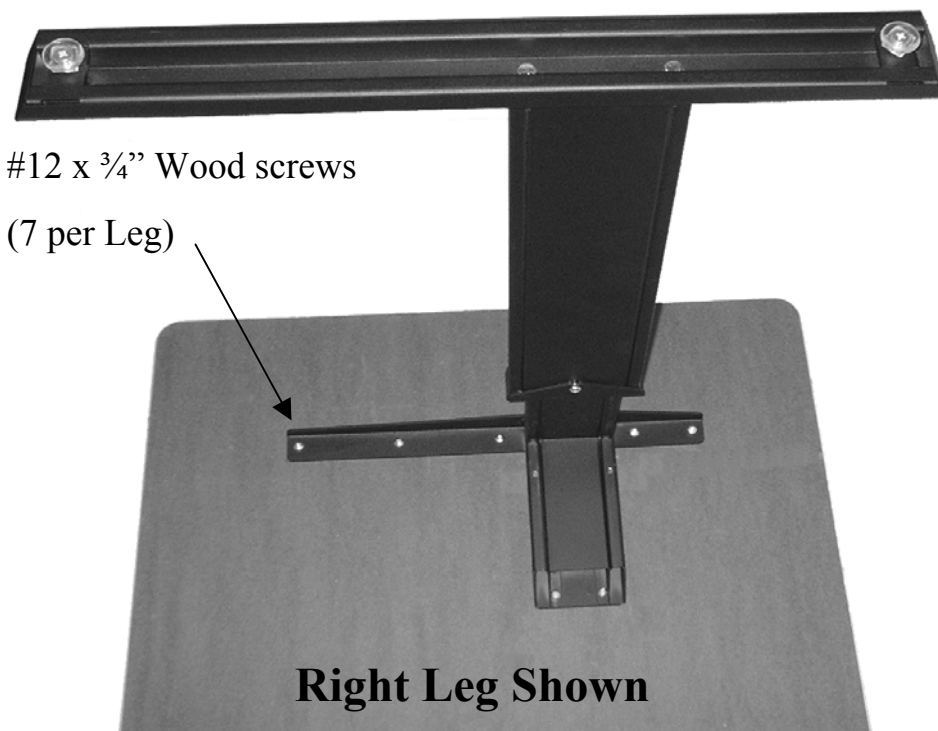
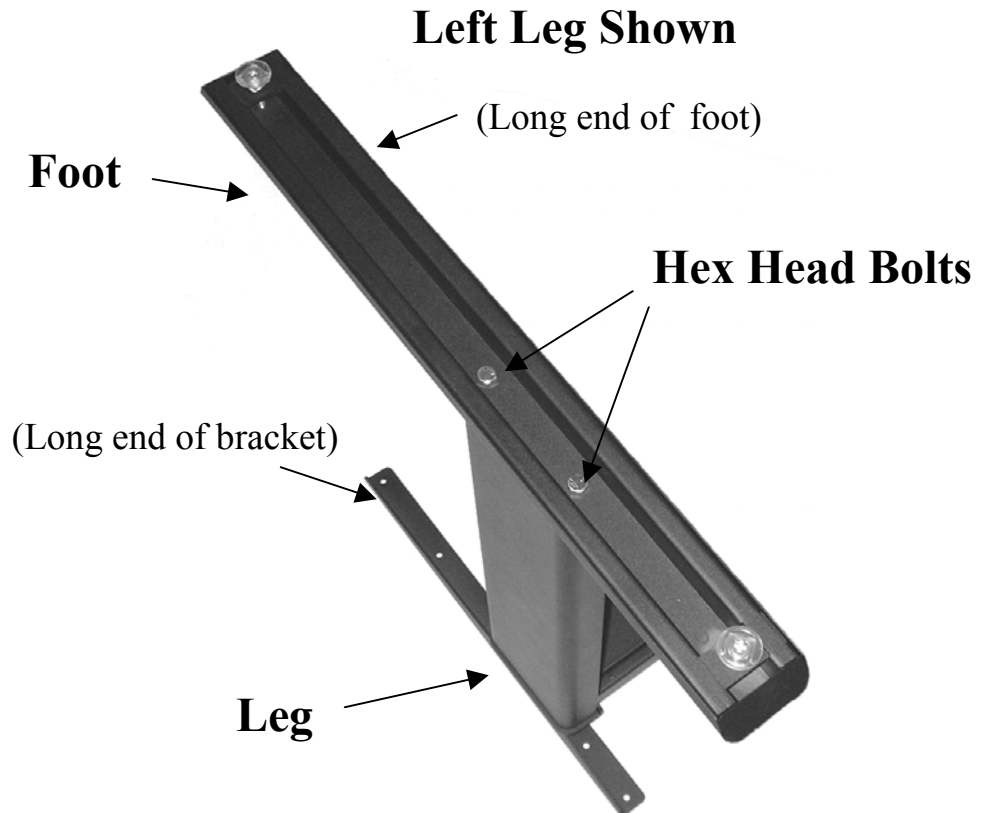

## Step 2.

Place the assembly onto an inverted top. If purchased with top included, simply line up the pre-drilled holes with the holes in the mounting bracket.

**NOTE:** *If attaching to tops 48" long or longer see Steps 4 and 5 on next page before proceeding.*

When adapting to existing tops, center the Leg and Foot assembly onto the top as shown. With a pencil, mark the centers of each hole and drill  $\frac{5}{32}$ " diameter by  $\frac{3}{4}$ " deep.

## Step 3.

Use the fourteen (14) #12 x  $\frac{3}{4}$ " wood screws included to attach the Leg and Foot assemblies to the top. **Do not over tighten.**

## Step 4.

When installing the Companion Base to work surfaces 48" long or longer, use the Cross Bar included. Line the holes in the end of the Cross bar with the holes on the Leg assemblies. Use the two (2) #10 x 1" Screws and attach both ends of the cross Bar to the Legs.

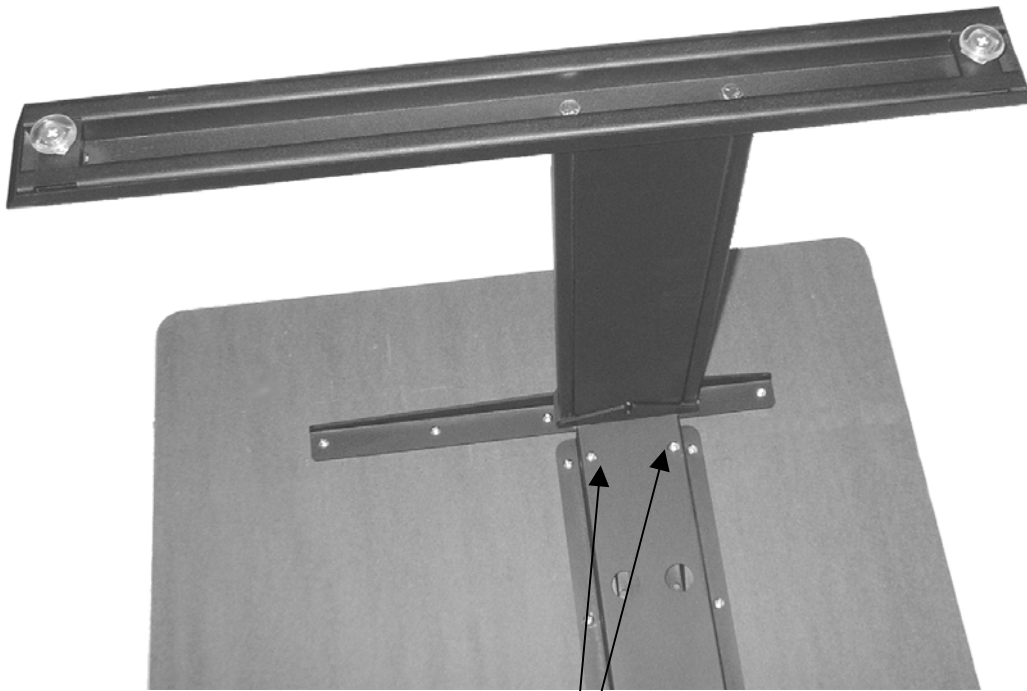

Line up the holes and attach using the #10 x 1" Screws

## Step 5.

With the remaining #12 x  $\frac{3}{4}$ " Wood Screws, stagger them along the Cross Bar, attaching the Cross Bar to the Top approximately every other hole.

**NOTE:** Tops purchased from WorkRite will be pre-drilled. If you are retrofitting an existing top then drill  $\frac{5}{32}$ " diameter holes  $\frac{3}{4}$ " deep.

## Step 4.

While table is still inverted, adjust the length of the Legs. The table height can be adjusted in one inch increments. From 23" to 34" in height. Pull up on the Foot until you reach the desired height. Align the hole and the Clamp Bracket with one of the Height Adjustment Holes located in a row. Use a #10 x 1" Screw and tighten.

To change the height, remove the screw and slide Leg to another height. Re-insert screw and tighten.

