

ELECTRALIFT™
SONOMA SERIES
2 LEG ASSEMBLY INSTRUCTIONS



WORKRITE®
ERGONOMICS

Sonoma Series Parts Listing

2 Leg System

AA) Top (size and shape differ for each model)



BB) End Brackets



QTY. 2

CC) Motorized Legs



QTY. 2

DD) Cross Bar (Length dependant upon model)



QTY. 1

EE) Feet (4" x 23") or (4" x 28")



QTY. 2

FF) 1/4-20 Cap Screws



QTY. 4

GG) 5/16-18 Dome Head Screws



QTY. 4

HH) 6mm x 16 Machine Screws (pre-installed)



QTY. 8

JJ) #12 x 3/4" Wood Screws



QTY. 18

KK) #8 x 1" Wood Screws



QTY. 4

LL) Wire Routing Clips



QTY. 15

MM) Control Box



QTY. 1

NN) Control Cables



QTY. 2 (Various Lengths)

OO) Key Pad and Cable



QTY. 1

PP) CAD Drawing of Table Plan View

QTY. 1

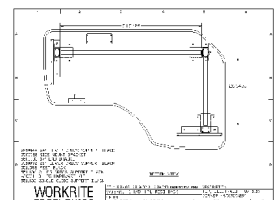

Note: Top and leg configurations are different for each model. See CAD drawing for your model configuration.

Sonoma Series ElectraLift™

Assembly Instructions

OPEN ALL PACKAGES AND VERIFY THAT YOU HAVE ALL THE HARDWARE AS INDICATED IN THE PARTS LISTING

Stop: If your table model has a multi-part top then refer to the instruction titled “Use of Draw Bolts for Joining Multi-Part Tops” and “Joining of Multi-Part Tops”.

TO ASSEMBLE, YOU WILL NEED A 5mm ALLEN WRENCH, A 6mm ALLEN WRENCH, A #2 TIP PHILIPS SCREWDRIVER, A #3 TIP PHILIPS SCREWDRIVER.

Step 1.) Remove the four (4) 6mm x 16mm Cap screws (HH) Use a 5mm Allen wrench
NOTE: Do not remove tape.

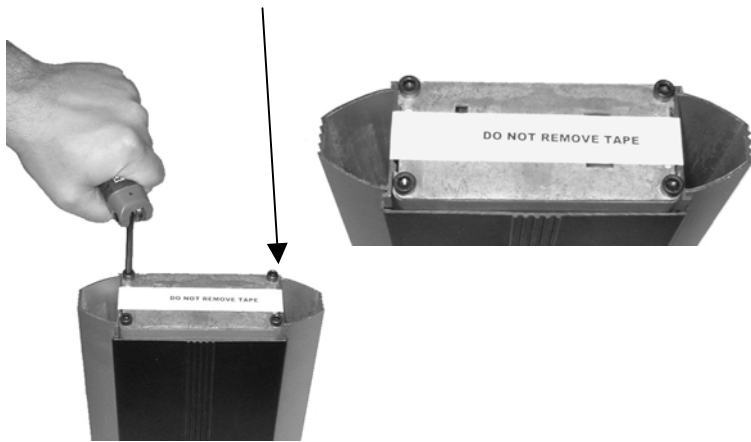

Step 2.) Slide the feet (EE) onto the leg. Be careful and take care not to force the foot on. Gently rock the foot into position.

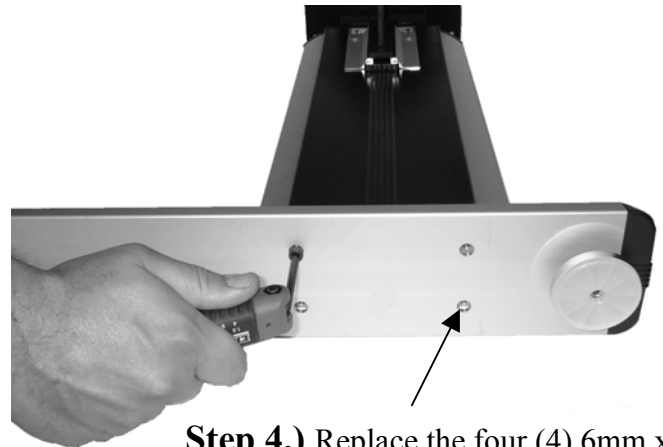

Step 4.) Replace the four (4) 6mm x 16mm Cap screws (HH). Tighten firmly

STEP 3. Slide the Cross Bar (DD) onto the mounting tab on the side of the Leg (CC). With a 3/16 Allen wrench, use the 5/16-18 Dome Head screws (GG) to attach. **Do not fully tighten until Step 4.** Depending on preference, the decorative side of the Cross Bar can be either facing the user or away from the user. The Cross Bar is universal. Repeat this procedure to connect the other Leg.

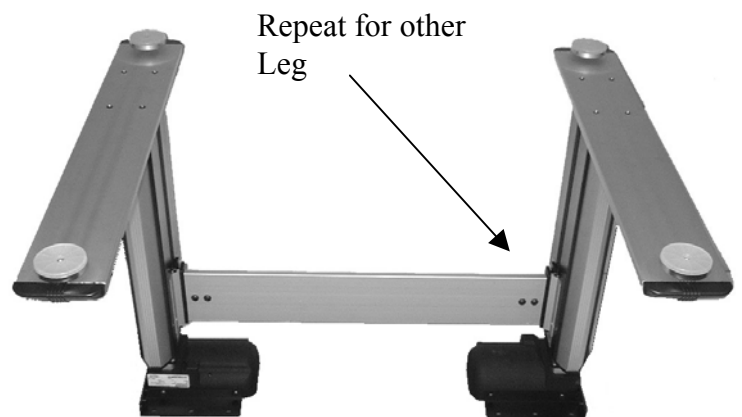
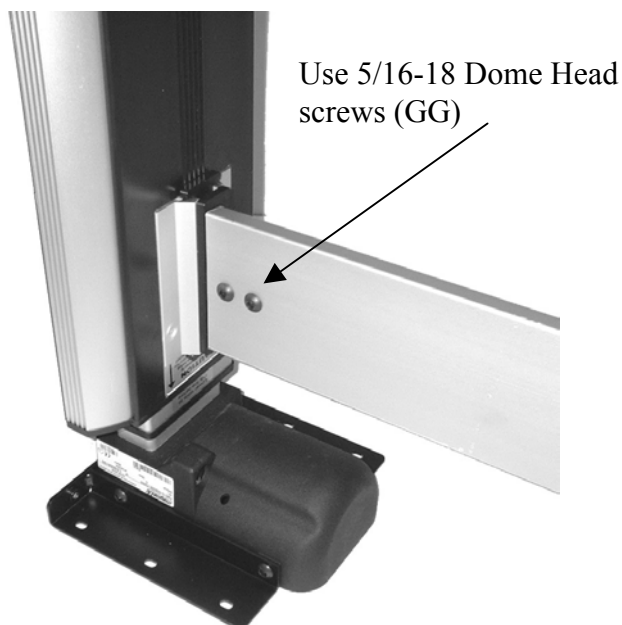

Note: Top and leg configurations are different for each model. See CAD drawing for your model configuration.

Sonoma Series ElectraLift™

Assembly Instructions

STEP 4. Prepare a flat surface. Make sure the area is free of debris that might scratch the finished surface. Place Top (AA) upside down for assembly. Place the leg assembly from Step 3 onto the work surface. Line up the pre-drilled holes with the holes in the mounting flanges. With a #3 Phillips tip screw driver, attach using the #12 x 3/4" wood screws (JJ). Repeat process on other leg. **DO NOT OVER TIGHTEN.** Now tighten the 5/16-18 Dome Head screws (GG) that attach the Cross Bar. **Tighten firmly.**

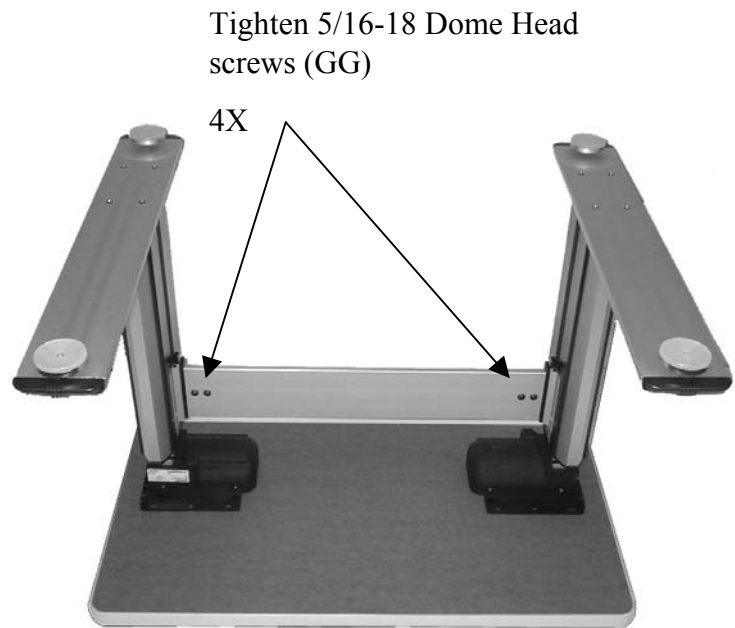
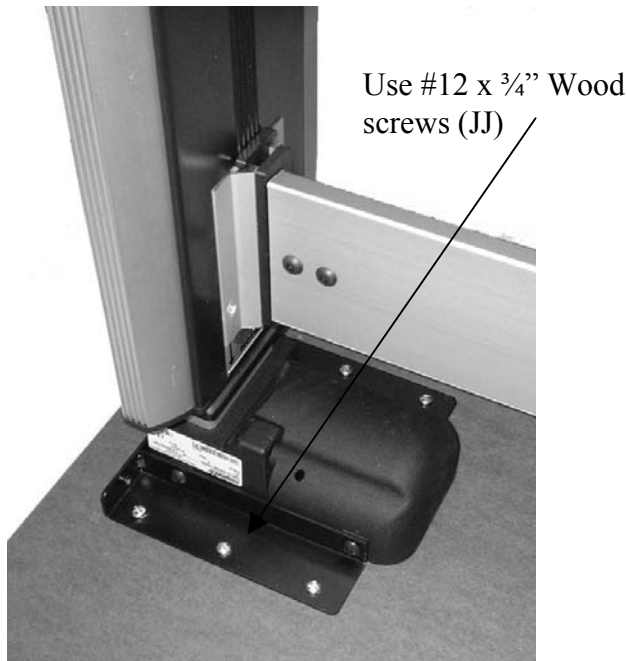

STEP 5. Attach the End Brackets (BB) by aligning the slots with the pre-drilled holes in the work surface. At the same time, two of the holes on the side of the End Bracket (BB) will line up with threaded inserts located on the leg mounting flange. Use the 1/4-20 Cap screws (FF). Tighten firmly. Now secure the bracket to the work surface using a #3 Phillips tip screw driver and the #12 x 3/4" Wood screws (JJ). **DO NOT OVER TIGHTEN.**

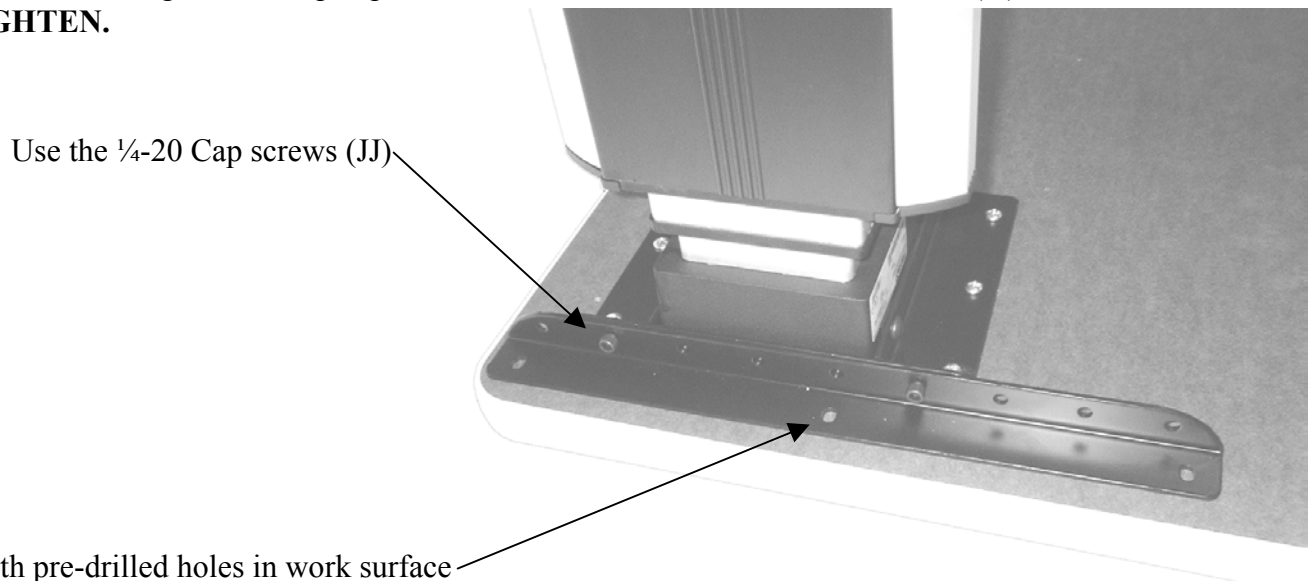

Note: Top and leg configurations are different for each model. See CAD drawing for your model configuration.

Sonoma Series ElectraLift™

Assembly Instructions

STEP 6.

Mount the Key Pad and Cable (OO) inserting three (3) #6 x 1" black wood screws (provided in package) into the pre-drilled holes at the front edge of the top, as shown in Figure 1. Do not over tighten. Over tightening can crack the mounting plate and inhibit the proper movement of the slide mount. Next mount the Control Box (MM) using four (4) #8 x 1" wood screws (KK) into the pre-drilled holes at the rear of the top (AA), as shown in Figure 2.

FIGURE 1

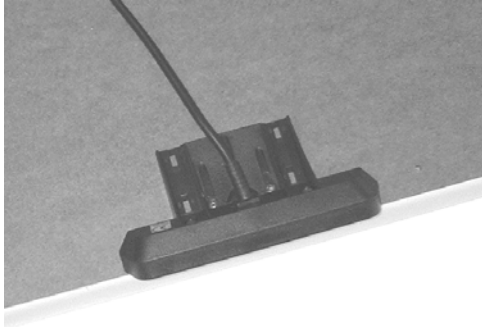
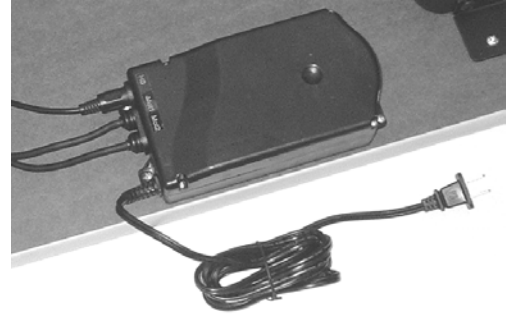

FIGURE 2



STEP 7.

Connect the control cables (NN) from the Legs (CC) to the Control Box (MM), being careful to line up the indentation on the Control Cable plug with the indentation on the leg receptor. Then connect the Key Pad (OO) to the Control Box (MM). The Control Cables (NN) are universal. The connections on the end are identical.



Plug the Key Pad (OO) to the Control Box (MM)

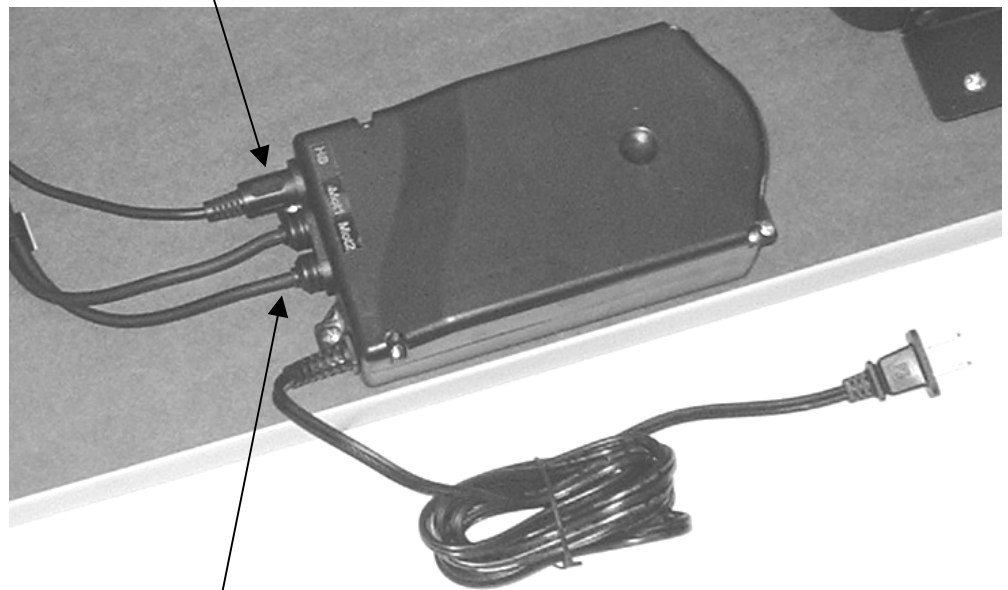

Plug the control Cables (NN) to the Control Box (MM)

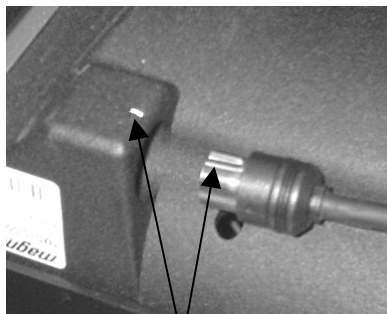

Line up the indentations on plug and receptor.

Note: Top and leg configurations are different for each model. See CAD drawing for your model configuration.

Sonoma Series ElectraLift™

Assembly Instructions

STEP 8.

Use the Wire Routing Clips (LL) to manage wire locations and excess lengths. Simply peel the Clips from the backer and press firmly to the work surface.

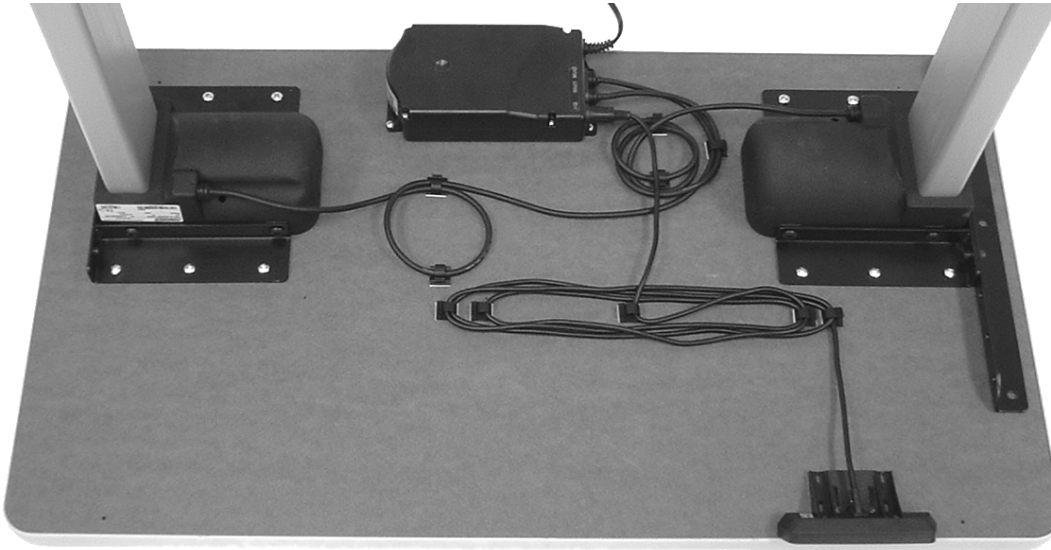

Simple peel and stick the Cord Routing Clip (LL) as needed.

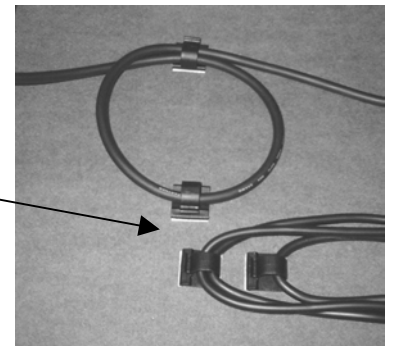

STEP 8. Use and Programming.

Use the Up and Down buttons to adjust height. Height will be displayed in inches. To program a desired height, move table height to a desired position and press the “S” button. An “S” appears in the Display. Then press any of the Preset buttons (1-4). You will hear two clicks indicating the preset was memorized. After about two seconds the display will show the current height. Repeat this process to program other preset positions. To adjust height to a preset position, simply press and hold the desired preset button until the work center reaches the preset height. If you release the button during travel, the table will stop.

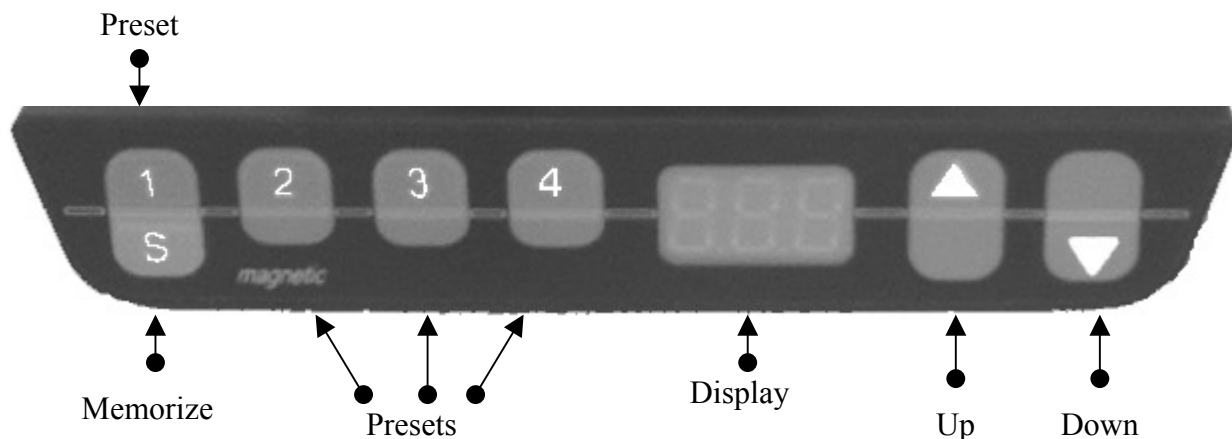

Note: Top and leg configurations are different for each model. See CAD drawing for your model configuration.