

Sonoma Premium

Adjustable Height Workcenters — Electric, Sit-to-Stand



Durable base supports up to 225 pounds of lifting capacity



Intuitive controls adjust height at 1.7" per second

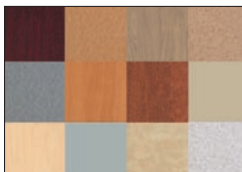

A sampling of the 56 standard laminates available



Quickly adjusts from seated to standing position

Integrity of Design and Performance

Offering height adjustment for the vast majority of workers and a stylish leg profile, the Premium is the premiere design solution. The stylish profile of the leg design is carried through all three stages of the adjustable leg, providing enhanced design integrity.

Adjust yourself to a new altitude (and attitude)

The ability to quickly and easily adjust from a seated to standing position makes the difference in motivating your employees to take a stand for comfort.

Something happens when your spine gets a lift - your outlook and productivity do, too

In today's competitive market for talent, an ergonomically sound workplace is one way to attract and retain top talent. (And counter the rising tide of workers' compensation claims.) Studies by leading health and safety experts underscore the health and productivity benefits of changing one's work posture from time to time. Sonoma Premium tables improve comfort and immediately convey your commitment to providing a safe, comfortable and productive environment.

Reasons for specifying a Premium Workcenter

Its sturdy motor quietly adjusts the worksurface and 225 pounds of additional capacity at a speed of 1.7" per second via intuitive up/down controls. To accommodate virtually any application, select from over 50 standard laminates and multiple trim options as well as bi-level versions for added flexibility. For preexisting installations, protect the investment in your worksurfaces by selecting a base-only version.

At Workrite we believe every body has a right to work comfortably and safely for maximum productivity. You can trust Workrite, as 75% of Fortune 100 companies have, for solutions that fit today's diverse range of workers.

Sonoma Premium Adjustable Height Workcenters — Electric, Sit-to-Stand

Statement of Line

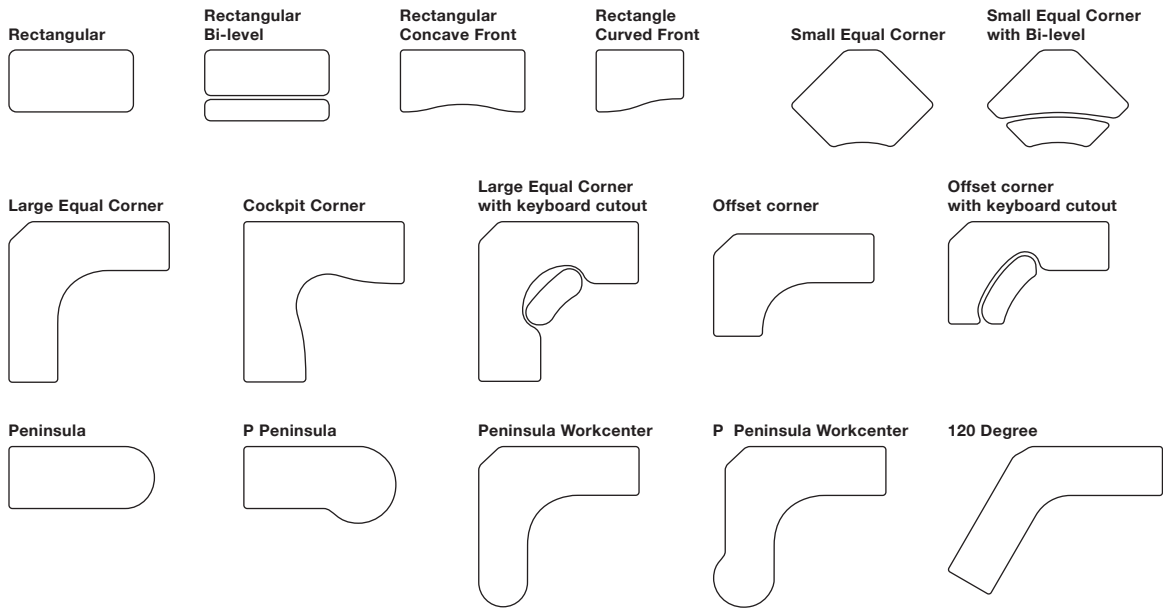

Key Dimensions

Height Range:
24½" – 51½"

with keyboard cutout:
18½" – 51½"

with bi-level surface:
18" – 57½"

Speed: 1.7" per second

Lifting Capacity: 225 lbs.

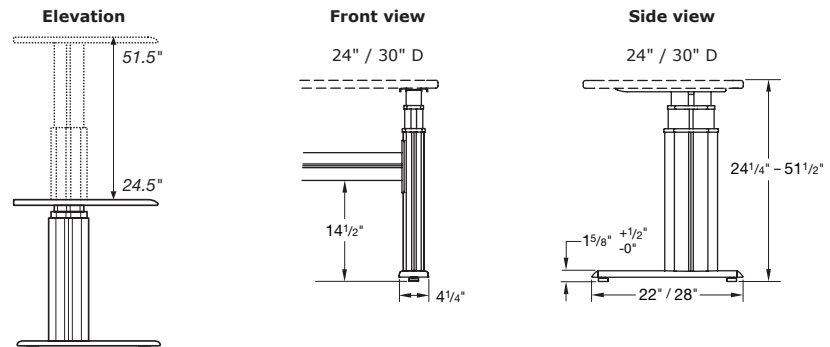

Color options: See "Color and Trim Options" section of the Pricing and Specification Guide for metal finishes, edge treatments and laminate options.

Dual surface specifications: Front surface laminate and trim matches main worksurface.
Bi-level tables: Front surface adjusted using Gemini 2420 arm with +6" to -6½" height range, and 15° to +15° tilt range.

Keyboard cutout: Front surface adjusted using fixed mount Pinnacle 2 arm with 0° to -6" height range, and 15° to +10° tilt range.

Adjustable glides: All tables have adjustable glides at front and back of each foot, providing ½" adjustment.

Worksurfaces: Are pre-drilled with mounting location for base and dual surface platform (if any).

Shipping: All tables and bases ship unassembled.

Control box: Powered by 120V / 60Hz. May draw 1.5 amps maximum under full load, idle current is typically 40mA; 102" two-prong power cord provided.

Cable management spool provided to manage excess control cables; optional cable mount accessories are available.

Application tips: Moving worksurfaces can collide with other components. Installation of overhead storage or wall mounted accessories in the path of the worksurface is not recommended. Workrite has tool bars which move with the worksurface and can accept a variety of desk accessories.

The following are federally registered trademarks of Workrite Ergonomics: Workrite Ergonomics®. The following are trademarks of Workrite Ergonomics: Sonoma Series™.

Printed with 25% post-consumer waste, 50% total recycled content.

1400208-0408 ©2008 Contents subject to change without notice.

Workrite Ergonomics, Inc.
1450 Technology Lane,
Petaluma, CA 94954
www.workriteergo.com
800.959.9675

Workrite
ergonomics®

